

JOINT APPLICATION FOR PERMITS

U.S. ARMY CORPS OF ENGINEERS - IDAHO DEPARTMENT OF WATER RESOURCES - IDAHO DEPARTMENT OF LANDS

Authorities: The Department of Army Corps of Engineers (Corps), Idaho Department of Water Resources (IDWR), and Idaho Department of Lands (IDL) established a joint process for activities impacting jurisdictional waterways that require review and/or approval of both the Corps and State of Idaho. Department of Army permits are required by Section 10 of the Rivers & Harbors Act of 1899 for any structure(s) or work in or affecting navigable waters of the United States and by Section 404 of the Clean Water Act for the discharge of dredged or fill materials into waters of the United States, including adjacent wetlands. State permits are required under the State of Idaho, Stream Protection Act (Title 42, Chapter 38, Idaho Code and Lake Protection Act (Section 58, Chapter 13 et seq., Idaho Code). In addition the information will be used to determine compliance with Section 401 of the Clean Water Act by the appropriate State, Tribal or Federal entity.

Joint Application: Information provided on this application will be used in evaluating the proposed activities. Disclosure of requested information is voluntary. Failure to supply the requested information may delay processing and issuance of the appropriate permit or authorization. **Applicant will need to send a completed application, along with one (1) set of legible, black and white (8 1/2"x11"), reproducible drawings that illustrate the location and character of the proposed project / activities to both the Corps and the State of Idaho.**

See **Instruction Guide** for assistance with Application. Accurate submission of requested information can prevent delays in reviewing and permitting your application. Drawings including vicinity maps, plan-view and section-view drawings must be submitted on 8-1/2 x 11 papers.

Do not start work until you have received all required permits from both the Corps and the State of Idaho

FOR AGENCY USE ONLY

USACE NWW-	Date Received:	<input type="checkbox"/> Incomplete Application Returned	Date Returned:
Idaho Department of Water Resources No.	Date Received:	<input type="checkbox"/> Fee Received DATE:	Receipt No.:
Idaho Department of Lands No.	Date Received:	<input type="checkbox"/> Fee Received DATE:	Receipt No.:

INCOMPLETE APPLICANTS MAY NOT BE PROCESSED

1. CONTACT INFORMATION - APPLICANT Required:				2. CONTACT INFORMATION - AGENT:				
Name: Dustin Kuttler				Name:				
Company: Skyline Holdings Group, LLC				Company:				
Mailing Address: [REDACTED]				Mailing Address:				
City: [REDACTED]		State: [REDACTED]	Zip Code: [REDACTED]	City:		State:	Zip Code:	
Phone Number (include area code): 801-550-3992		E-mail: kuttidustin@gmail.com		Phone Number (include area code):		E-mail:		
3. PROJECT NAME or TITLE: Skyline View Ranch				4. PROJECT STREET ADDRESS: 2250 S 5000W				
5. PROJECT COUNTY: Teton County		6. PROJECT CITY: Driggs		7. PROJECT ZIP CODE: 83422		8. NEAREST WATERWAY/WATERBODY:		
9. TAX PARCEL ID#: RP04N44E120150		10. LATITUDE: 43.693801 LONGITUDE: -111.207567		11a. 1/4: NE	11b. 1/4: NW	11c. SECTION: 12	11d. TOWNSHIP: 4 North	11e. RANGE: 44 East
12a. ESTIMATED START DATE: 8/1/2024		12b. ESTIMATED END DATE: 7/30/2025		13a. IS PROJECT LOCATED WITHIN ESTABLISHED TRIBAL RESERVATION BOUNDARIES? <input checked="" type="checkbox"/> NO <input type="checkbox"/> YES Tribe:				
13b. IS PROJECT LOCATED IN LISTED ESA AREA? <input checked="" type="checkbox"/> NO <input type="checkbox"/> YES				13c. IS PROJECT LOCATED ON/NEAR HISTORICAL SITE? <input checked="" type="checkbox"/> NO <input type="checkbox"/> YES				
14. DIRECTIONS TO PROJECT SITE: Include vicinity map with legible crossroads, street numbers, names, landmarks. 2250 S 5000 W Driggs Idaho. Mahogany creek crosses 2250 S around 1800 feet west of the intersection of 2250 S and 5000 W.								
15. PURPOSE and NEED: <input type="checkbox"/> Commercial <input type="checkbox"/> Industrial <input type="checkbox"/> Public <input checked="" type="checkbox"/> Private <input type="checkbox"/> Other Describe the reason or purpose of your project; include a brief description of the overall project. Continue to Block 16 to detail each work activity and overall project. This application is for a private crossing to access two 20 acre parcels using a box culvert system to cross a previously channelized section of Mahogany Creek in Teton County								

16. DETAILED DESCRIPTION OF EACH ACTIVITY WITHIN OVERALL PROJECT. Specifically indicate portions that take place within waters of the United States, including wetlands: Include dimensions; equipment, construction, methods, erosion, sediment and turbidity controls; hydrological changes: general stream/surface water flows, estimated winter/summer flows; borrow sources, disposal locations etc.:

Mahogany creek is a seasonal stream that has been channelized through this property. This crossing will access two 20 acre parcels that may have an single residence built in the future on each lot. An engineer has prepared the plans and are attached to this application. A digital pdf file has also been sent with materials and sizes of all culverts and material that will be used. The box culvert is 7 feet high, and 11 feet wide and spans 39 feet to accommodate the 20 ft crossing, 6 feet of shoulder and additional footage due to the angle of the access.

All work will be preformed using a backhoe and front end loader working from either side of the bank. There is a county road 1000 ft away with an existing crossing to provide access. The crossing is required by the Teton county due to an ordinance that requires all lots in a development to have access from withing the development

As mahogany creek is seasonal all work will be preformed when no water is flowing

17. DESCRIBE ALTERNATIVES CONSIDERED to AVOID or MEASURES TAKEN to MINIMIZE and/ or COMPENSATE for IMPACTS to WATERS of the UNITED STATES, INCLUDING WETLANDS: See Instruction Guide for specific details.

In order to minimize impact work will be done while little to no water is present. work will be preformed from the top of the bank to and silt fencing and straw barriers will be used to minimize debris flow

18. PROPOSED MITIGATION STATEMENT or PLAN: If you believe a mitigation plan is not needed, provide a statement and your reasoning why a mitigation plan is NOT required. Or, attach a copy of your proposed mitigation plan.

AS the creek is dry from July to November we plan on completing the work during this time. The total time needed would be 10 working days or less, silt fencing and erosion control would be provided during the construction process.

19. TYPE and QUANTITY of MATERIAL(S) to be discharged below the ordinary high water mark and/or wetlands:

Dirt or Topsoil: 0 cubic yards
 Dredged Material: _____ cubic yards
 Clean Sand: 0 cubic yards
 Clay: 0 cubic yards
 Gravel, Rock, or Stone: 0 cubic yards
 Concrete: 0 cubic yards
 Other (describe): _____ : 0 cubic yards
 Other (describe): _____ : 0 cubic yards

TOTAL: 0 cubic yards

20. TYPE and QUANTITY of impacts to waters of the United States, including wetlands:

Filling: _____ acres _____ sq ft _____ cubic yards
 Backfill & Bedding: 0.01 acres 0.009 sq ft. 42 cubic yards
 Land Clearing: 0.01 acres 440 sq ft. 103 cubic yards
 Dredging: _____ acres _____ sq ft. _____ cubic yards
 Flooding: _____ acres _____ sq ft. _____ cubic yards
 Excavation: 0.01 acres 440 sq ft. 42 cubic yards
 Draining: _____ acres _____ sq ft. _____ cubic yards
 Other: _____ : _____ acres _____ sq ft. _____ cubic yards

TOTALS: 0.03 acres 880.009 sq ft. 187 cubic yards

21. HAVE ANY WORK ACTIVITIES STARTED ON THIS PROJECT? NO YES If yes, describe ALL work that has occurred including dates.

22. LIST ALL PREVIOUSLY ISSUED PERMIT AUTHORIZATIONS:

23. YES, Alteration(s) are located on Public Trust Lands, Administered by Idaho Department of Lands

24. SIZE AND FLOW CAPACITY OF BRIDGE/CULVERT and DRAINAGE AREA SERVED: 9.69 Square Miles

25. IS PROJECT LOCATED IN A MAPPED FLOODWAY? NO YES If yes, contact the floodplain administrator in the local government jurisdiction in which the project is located. A Floodplain Development permit and a No-rise Certification may be required.

26a WATER QUALITY CERTIFICATION: Pursuant to the Clean Water Act, anyone who wishes to discharge dredge or fill material into the waters of the United States, either on private or public property, must obtain a Section 401 Water Quality Certification (WQC) from the appropriate water quality certifying government entity. See *Instruction Guide for further clarification and all contact information.*

The following information is requested by IDEQ and/or EPA concerning the proposed impacts to water quality and anti-degradation:
 NO YES Is applicant willing to assume that the affected waterbody is high quality?
 NO YES Does applicant have water quality data relevant to determining whether the affected waterbody is high quality or not?
 NO YES Is the applicant willing to collect the data needed to determine whether the affected waterbody is high quality or not?

26b. BEST MANAGEMENT PRACTICES (BMP's): List the Best Management Practices and describe these practices that you will use to minimize impacts on water quality and anti-degradation of water quality. All feasible alternatives should be considered - treatment or otherwise. Select an alternative which will minimize degrading water quality

Silt fencing and erosion control will be used to limit impacts on the creek bed. All equipment will remain outside the creek channel to minimize impact. Work will be done when little to no water is present. When first contacted the state of Idaho said they did not have jurisdiction over this section of water but they determined that they would like jurisdiction. This section of stream has been channelized in the past and has numerous crossings for irrigation systems and canal diversions

Through the 401 Certification process, water quality certification will stipulate minimum management practices needed to prevent degradation.

27. LIST EACH IMPACT to stream, river, lake, reservoir, including shoreline. Attach site map with each impact location.

Activity	Name of Water Body	Intermittent Perennial	Description of Impact and Dimensions	Impact Length Linear Feet
Excavation	Mahogany Creek		bank excavation 7feet high 11 feet wide 40 feet long	
Culvert Installation	Machogany Creek		Box culvert 7 feethigh 11 feet wide 40 feet long	40
TOTAL STREAM IMPACTS (Linear Feet):				40

28. LIST EACH WETLAND IMPACT include mechanized clearing, fill, excavation, flood, drainage, etc. Attach site map with each impact location.

Activity	Wetland Type: Emergent, Forested, Scrub/Shrub	Distance to Water Body (linear ft)	Description of Impact Purpose: road crossing, compound, culvert, etc.	Impact Length (acres, square ft linear ft)
TOTAL WETLAND IMPACTS (Square Feet):				

29. ADJACENT PROPERTY OWNERS NOTIFICATION REQUIREM: Provide contact information of ALL adjacent property owners below.

Name: Leora Wood Mailing Address: [REDACTED] City: [REDACTED] State: [REDACTED] Zip Code: [REDACTED] Phone Number (include area code): [REDACTED] E-mail: [REDACTED]	Name: RiverBend Holdings LLC Mailing Address: [REDACTED] City: [REDACTED] State: [REDACTED] Zip Code: [REDACTED] Phone Number (include area code): [REDACTED] E-mail: [REDACTED]
Name: Tyler Pulley Mailing Address: [REDACTED] City: [REDACTED] State: [REDACTED] Zip Code: [REDACTED] Phone Number (include area code): [REDACTED] E-mail: [REDACTED]	Name: 862 Teton LLC Mailing Address: [REDACTED] City: [REDACTED] State: [REDACTED] Zip Code: [REDACTED] Phone Number (include area code): [REDACTED] E-mail: [REDACTED]
Name: Gardner Perry Mailing Address: [REDACTED] City: [REDACTED] State: [REDACTED] Zip Code: [REDACTED] Phone Number (include area code): [REDACTED] E-mail: [REDACTED]	Name: George Bates Mailing Address: [REDACTED] City: [REDACTED] State: [REDACTED] Zip Code: [REDACTED] Phone Number (include area code): [REDACTED] E-mail: [REDACTED]
Name: Jason Nicholson Mailing Address: [REDACTED] City: [REDACTED] State: [REDACTED] Zip Code: [REDACTED] Phone Number (include area code): [REDACTED] E-mail: [REDACTED]	Name: C2H2 Land Ventures Mailing Address: [REDACTED] City: [REDACTED] State: [REDACTED] Zip Code: [REDACTED] Phone Number (include area code): [REDACTED] E-mail: [REDACTED]

30. SIGNATURES: STATEMENT OF AUTHORIZATION / CERTIFICATION OF AGENT / ACCESS

Application is hereby made for permit, or permits, to authorize the work described in this application and all supporting documentation. I certify that the information in this application is complete and accurate. I further certify that I possess the authority to undertake the work described herein; or am acting as the duly authorized agent of the applicant (Block 2). I hereby grant the agencies to which this application is made, the right to access/come upon the above-described location(s) to inspect the proposed and completed work/activities.

Signature of Applicant: [Handwritten Signature]

Date: 7-9-2029

Signature of Agent: [Handwritten Signature]

Date: 7-9-2029

This application must be signed by the person who desires to undertake the proposed activity AND signed by a duly authorized agent (see Block 1, 2, 30). Further, 18 USC Section 1001 provides that: "Whoever, in any manner within the jurisdiction of any department of the United States knowingly and willfully falsifies, conceals, or covers up any trick, scheme, or disguises a material fact or makes any false, fictitious, or fraudulent statements or representations or makes or uses any false writing or document knowing same to contain any false, fictitious or fraudulent statements or entry, shall be fined not more than \$10,000 or imprisoned not more than five years or both".



STATE MAP



VICINITY MAP

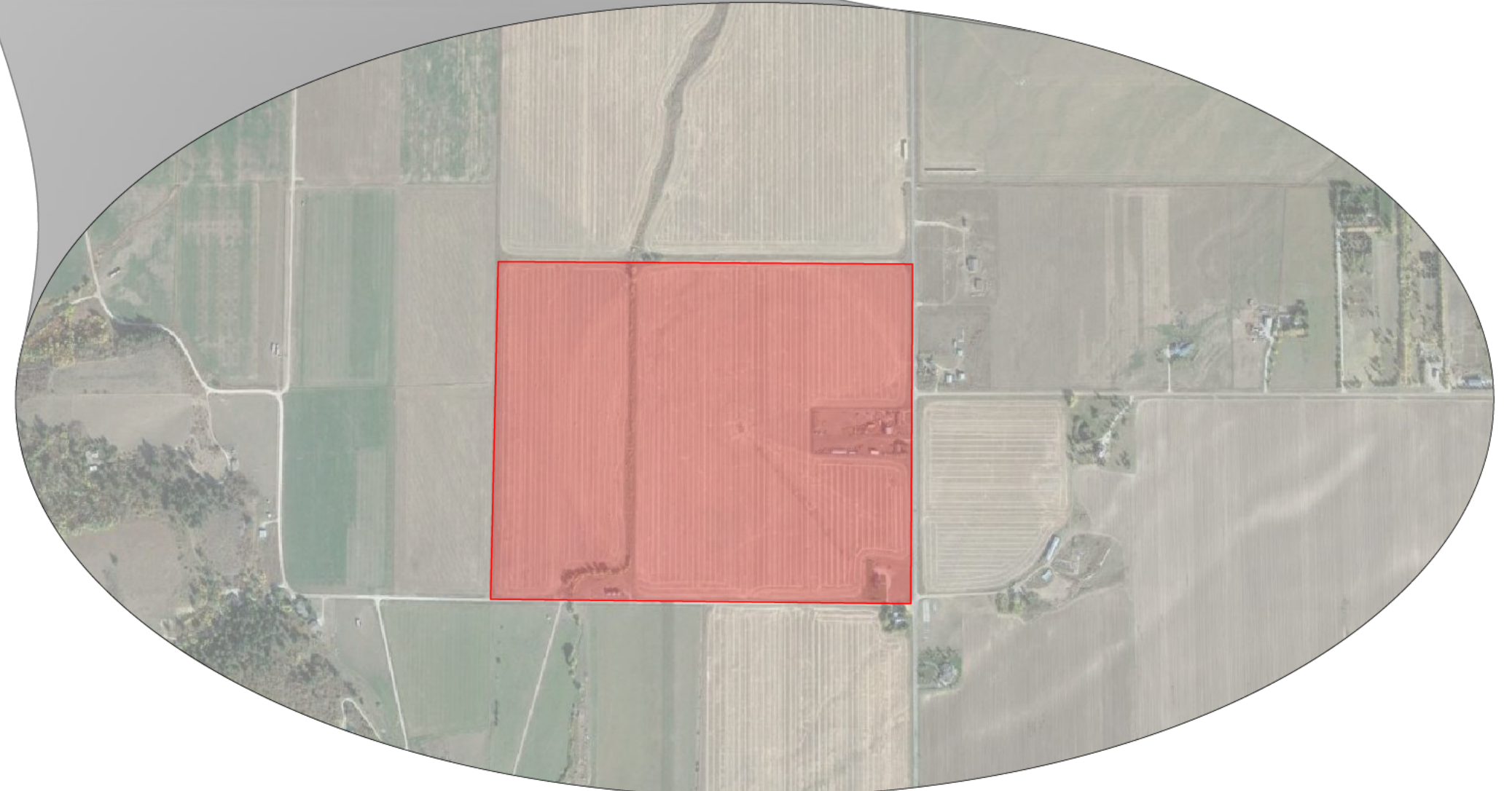

SITE MAP

DEVELOPMENT DRAWINGS FOR:
SKYLINE VIEW RANCH
TETON COUNTY, ID

CONNECT ENGINEERING
The Civil Connection
 2295 N Yellowstone HWY, Unit 6
 Idaho Falls, ID 83401
 208.881.0081

APPROVAL SIGNATURES:	
	Connect Engineering _____ Date: _____ TETON COUNTY, ID _____ Date: _____

SHEET NO.
C-1 of 14

GENERAL NOTES

- All materials, workmanship, and construction of site improvements shall meet or exceed the work standards and specifications set forth by TETON COUNTY STANDARD DRAWINGS AND SPECIFICATIONS, and requirements of the Idaho Standards for Public Works Construction, (ISPWC) current edition.
- All material furnished on or for the project must meet the minimum requirements of the approving agencies or as set forth herein, whichever is more restrictive.
- The Contractor is cautioned that the location and/or elevation of existing utilities, as shown on these plans, is based on records of the various utility companies and where possible, measurements taken in the field. The Contractor must call the local utility location center at least 48 hours before any excavation to request exact field locations of the utilities.
- A Pre-Construction Conference shall be held a minimum of three (3) working days prior to start of work. All Contractors, Subcontractors and/or Utility Contractors shall be present.
- All lot dimensions and easements are to be taken from the Final Plat of the recorded subdivision plat.
- The Contractor shall maintain all existing drainage and sanitary sewer facilities within the construction area until the drainage improvements are in place and functioning.
- All Contractors working within the project boundaries are responsible for compliance with all applicable safety laws of any jurisdictional body including but not limited to, barricades, safety devices, control of traffic, excavation, trenching, shoring, and security within and around the construction area.
- Contractors must furnish proof that all materials installed on this project meet the requirements of Note # 2 above at the request of the agency and/or Engineer.
- CONNECT ENGINEERING must give approval prior to (a) backfilling trenches for pipe; (b) placing of aggregate base; (c) placing of concrete; (d) placing of asphalt pavement. Work done without such approval shall not relieve the Contractor from the responsibility of performing the work in an acceptable manner. Contract work will not be accepted by TETON COUNTY without the approval of the Project Engineer.
- Developmental drawings must be submitted to TETON COUNTY Public Works Dept. prior to final approval.
- Only plan sets marked "Approved for Construction" shall be used by the project contractor(s). Use of any plans on the job without the "Approved for Construction" stamp shall be grounds for the issuance of a stop work order. Contractor must also maintain a set of plans stamped with approval by the Department of Environmental Quality on site.
- Contractor is responsible for property corner protection. The cost of \$30 per corner will be held as retainage until all interior corners are verified to be in place.
- Each Contractor shall be responsible for acquiring any necessary NPDES permits, filing any NOI's or NOT's, and preparing a Storm Water Pollution Prevention Plan (SWPPP) in accordance with the Environmental Protection Agency. Contact the EPA at 208.378.5776 for the required information. Said permit shall be presented to the Engineer at least forty-eight (48) hours prior to the beginning of construction.
- The Contractor shall be responsible for keeping roadways free and clear of all construction debris and dirt tracked in from the site.
- All measures possible shall be taken to ensure erosion control with Best Management Practices.
- Quantities shown are estimates by the Engineer. The Contractor must verify all quantities. If there is a large discrepancy contact the Engineer.
- All work must meet standards set forth by the American Disabilities Act (ADA) inside public rights of way.
- Trench backfill Type 2A compaction "Water Settling" will not be an acceptable method of trench backfill compaction.
- All water valves, blow-offs and manholes will be placed so as not to conflict with any concrete curb, gutter, valley gutter, and sidewalk improvements.
- CONNECT ENGINEERING and/or Inspector shall make periodic visits to the project location to ensure that the site improvements meet or exceed standards and design as per the approved construction drawings.
- To receive final acceptance, Contractor must submit copy of field plans complete with construction notes and As-Built information, corrections, changes, etc.
- Contractor must have ISPWC manual (current edition) on-site during all phases of construction. Failure to do so may result in non-acceptance of the site by DEQ, Engineer, City etc.
- A copy of the Quality Control Signature sheet (with all applicable signatures) shall be delivered to CONNECT ENGINEERING prior to the walk-thru.
- A Right-of-Way Construction Permit from TETON COUNTY Public Works is required for any construction in the road right-of-way not shown on these improvement drawings.
- Contractors shall provide a one (1) year warranty on all roads from the date of formal acceptance by TETON COUNTY.
- Lot corners and centerline intersection monuments have been staked as shown on the recorded plat of this subdivision. Should any of these monuments be lost or disturbed during construction Idaho Code 55-1613 requires said monuments will be reestablished by a professional land surveyor at the expense of the agency or person causing the loss or disturbance.
- All Construction Staking shall be provided by the owner one time, but if restaking is required this shall be provided at the Contractors expense.
- It is the contractors responsibility to know which permits are needed and obtain all construction permits including ROW for bore.
- Plans are intended to be printed in color for added clarity of design.

ELECTRICAL NOTES

- All new electrical facilities shall be constructed in accordance with the current Falls River Power Service Policy. Coordinate all electrical construction with Falls River Power.
- Primary sectionalizing cabinets, transformer ground sleeves, secondary pedestals, fiber boxes, and ground rods shall be provided by IFF, but shall be picked up at the IFF warehouse and/or west side yard and installed by the Contractor.
- All PVC electric conduits shall be PVC Schedule 40 (see note 5 and 6 for exceptions). All elbows shall be PVC Schedule 40 large radius sweep (36") or as otherwise specified by IFF (see note 5 and 6 for exceptions). RGS conduit must be used at riser poles. Conduits must be capped and labeled to identify routing.
- The minimum power trench shall have a minimum depth of fifty-four inches (54") and maximum depth of sixty inches (60") below finish grade (Conduit to be installed 48" below finish grade). Including 6" of sand bedding below and above top of conduits. Minimum trench width shall be twenty-four inches (24"), unless otherwise noted. All Primary conduit must have a minimum of one (1) foot separation between other conduits in trench. Bottom of trenches must be level for conduit installation. All trenches and conduits (including road crossings) must be inspected by Idaho Falls Power prior to back-filling. Backfill and compact all trenches to a minimum of 95% of max density. (Secondary conduits can be reduced to 30" of cover).
- Minimum conduit depth can be reduced to eighteen inches (18") of cover below final grade through basalt or other rock upon prior approval of IFF. Rigid galvanized steel (RGS) conduit shall be provided and installed by the Contractor. IFF will specify the conduit size.
- 2" HDPE SDR 13.5 continuous duct with pre-lubricated ribbed interior wall can be utilized by the Contractor instead of 2 1/2" PVC Schedule 40 as specified on the Contractor Map for proposed 1/0 single phase primary conductor. Conduit to be red in color or black with red stripes (red conduit preferred). If possible HDPE to be ordered with "IFF" stamped on conduit. The HDPE can be turned up inside of ground sleeves or Contractor may transition to 2" PVC Schedule 40 large radius sweep (36") with Perma-Guard/UL fittings by Amco Shur-Lock II or approved equal by IFF.
- Contractor / Developer to install a 2500 lb mule tape string through each primary power conduit run more than 75 LF, all services from the meter base to the transformer / secondary pedestal, and install pull string for fiber optic conduit runs.
- The Developer/Contractor shall provide all staking and layout of new electrical and fiber facilities including power poles. All lot corners adjacent to all power trenches must be clearly marked for installation of electrical facilities.
- The Contractor shall retain and protect all existing City power poles and electrical and fiber facilities during construction. Also, repair / replace all concrete, asphalt, and landscaping that is disturbed during construction.
- It shall be the Customer or Contractor's responsibility to provide illumination (street lights) along or within the public rights-of-way contained within a new development.
- All new light pole foundations and lighting conduits shall be constructed by the Contractor in accordance with current Falls River standard drawings and specifications. IFF will furnish to the Contractor a bolt hole template (pending availability), anchor bolts, nuts, washers, grounding butt plate, and ground wire needed for the installation of the light poles.
- IFF will install poles and luminaires with the cost of materials paid by the Contractor prior to installation.
- On all subdivisions the padmounted equipment (including ground sleeves / pedestals, etc.) will not be provided or set until curb and gutter has been installed. Idaho Falls Power will provide ground rods and contractor will install ground rods prior to installation of conduit.
- On buildings serving 3 units or more, meter sockets and units must be PERMANENTLY labeled prior to meters being energized. Electrician will be required to coordinate with Idaho Falls Power in order to verify meter socket is connected to correct unit (208-612-8207).

SEPTIC NOTES

- All properties will have private septic at the responsibility of the lot owner

WATER NOTES

- All properties will have private well at the responsibility of the lot owner.

STREET CONSTRUCTION

- All construction within public right-of-way shall conform to the current edition of the ISPWC and Teton County standards. No exceptions to Policy Standards and the ISPWC will be allowed unless specifically and previously approved in writing by Teton County.
- No construction shall begin before the Pre-Construction meeting, which the Contractor is required to attend.
- All reinforced concrete pipe shall conform to ASTM C-76 Specifications for the class of pipe indicated, and shall be installed watertight.
- All work will be inspected by CONNECT ENGINEERING and monitored by Teton County in accordance with the latest edition of the Teton County Standard Drawings and Specifications.
- Borrow shall be obtained from sources designated or approved in writing by the Engineer.
- Clearing and grubbing shall consist of removing all natural and artificial objectionable materials. Under no circumstances shall roadways be placed on frozen or objectionable material.
- The subgrade shall be excavated and bladed to remove all uneven areas and to secure a uniform surface true to grade and line. The subgrade material shall then be scarified to a depth of eight inches (8"), adjusted to within approximately 2% of optimum moisture content and compacted to the minimum density required as stated in ISPWC.
- All road stripping and excess topsoil shall be stockpiled out of the right-of-way and stored at Contractor's expense.
- A traffic control plan based on the latest edition of the Manual on Uniform Traffic Control Devices (MUTCD) shall be approved by Teton County Public Works Department prior to construction.
- Parked equipment and stored materials shall be kept as far away from the travel way as feasible. Items left overnight within 30 feet of the travel way shall be marked and/or protected.
- Contractor responsible for all traffic control plans and implantation.

STREET SIGNING

- All road striping and traffic signing shall be designed, constructed, and placed according to the current Manual of Uniform Traffic Control Devices (MUTCD) with the following exceptions: All Stop and Yield signs used in any subdivision shall be a minimum 30" X 30", engineer grade sheeting is not allowed.
 - All Road Name and Street signs shall have a minimum 4" legend. Both background and legend shall be retro-reflective. Standard colors are white legend and green background except private roads, which will have a blue background.
 - Substrate material shall be aluminum; no fiberglass or plastic will be accepted.
 - The minimum size for Speed Limit Signs shall be 24"W X 30"L with black legend on white background.
 - Posts shall be metal and shall be anchored with a "soil type" anchor. No concrete shall be used as an anchor. Posts shall be 2" X 2" square and must meet break-a-way standards of the State of Idaho. No U-channel shall be used.
 - The minimum height of signs shall be 6' from the road surface to the bottom of the sign.
 - Maintenance of all street and traffic signs will be the responsibility of the developer until the streets are officially accepted for maintenance by Teton County.

CONTACTS

DEPARTMENT OF ENVIRONMENTAL QUALITY
 900 N SKYLINE, SUITE B
 IDAHO FALLS, IDAHO 83402
 (208) 528-2650

TETON COUNTY COURT HOUSE
 150 COURTHOUSE DRIVE
 ROOM 107
DRIGGS, ID
208-354-2593

Silver Star Communications
 1670 ID-33
 Driggs, ID 83422
 (208) 354-3300

Falls River POWER
 1605 N HWY. 33
 P.O. Box 511 Driggs, ID 83422
 208-652-7431

	DRAWN BY	CHECK BY
	MAK / AQT	BDJ
	REVISIONS	DATE



SHEET NAME:	NOTES
PROJECT:	SKYLINE VIEW RANCH
LOCATION:	TETON COUNTY, ID

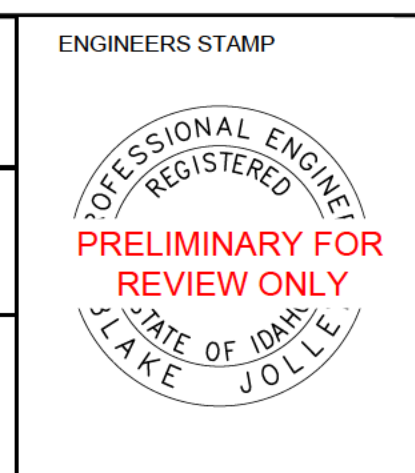

ENGINEERS STAMP	SHEET INFORMATION
	JOB NO: 2021-105
	DATE: July 1, 2024
	SHEET SIZE: 24X36
	VERTICAL EXAGGERATION: 1V = 10 H
PROJECT CONTACT:	BARRY BAME CONNECT ENGINEERING 208-881-0881

SHEET	C-2
OF	14
SHEETS	

REFERENCES

RETAIN AND PROTECT

100-1 RETAIN AND PROTECT

EARTHWORK

200-1 SAW-CUT LINE AND ASPHALT REMOVAL AND UTILITY TRENCH PER ISPMC SD - 306

WATER

401-6 INSTALL 6" WATER PIPE C-50 DI @ 6' MINIMUM COVER PER ISPMC

401-8 INSTALL 8" WATER PIPE C-50 DI @ 6' MINIMUM COVER PER ISPMC

401-10 INSTALL 10" WATER PIPE C-50 DI @ 6' MINIMUM COVER PER ISPMC

401-12 INSTALL 12" WATER PIPE C-50 DI @ 6' MINIMUM COVER PER ISPMC

401-8.6 INSTALL 8" TO 6" C50-DI REDUCER WITH THRUST BLOCK PER ISPMC SD - 403

401-6.6.6 INSTALL 6"x6"x6" TEE WITH THRUST BLOCK PER ISPMC SD - 403

401-8.8.8 INSTALL 8"x8"x8" TEE WITH THRUST BLOCK PER ISPMC SD - 403

401-12.12.12 INSTALL 12"x12"x12" TEE WITH THRUST BLOCK PER ISPMC SD - 403

401-8.8.6 INSTALL 8"x8"x6" TEE WITH THRUST BLOCK PER ISPMC SD - 403

401-12.12.6 INSTALL 12"x12"x6" TEE WITH THRUST BLOCK PER ISPMC SD - 403

401-12.12.8 INSTALL 12"x12"x8" TEE WITH THRUST BLOCK PER ISPMC SD - 403

401-6.11 INSTALL 6" 11.25" BEND WITH THRUST BLOCK PER ISPMC SD - 403

401-6.22 INSTALL 6" 22.5" BEND WITH THRUST BLOCK PER ISPMC SD - 403

401-6.45 INSTALL 6" 45" BEND WITH THRUST BLOCK PER ISPMC SD - 403

401-6.90 INSTALL 6" 90" BEND WITH THRUST BLOCK PER ISPMC SD - 403

401-8.11 INSTALL 8" 11.25" BEND WITH THRUST BLOCK PER ISPMC SD - 403

401-8.22 INSTALL 8" 22.5" BEND WITH THRUST BLOCK PER ISPMC SD - 403

401-8.45 INSTALL 8" 45" BEND WITH THRUST BLOCK PER ISPMC SD - 403

401-8.90 INSTALL 8" 90" BEND WITH THRUST BLOCK PER ISPMC SD - 403

402-6 INSTALL 6" WATER VALVE PER ISPMC SD - 406

402-8 INSTALL 8" WATER VALVE PER ISPMC SD - 406

402-12 INSTALL 12" WATER VALVE PER ISPMC SD - 406

403-1 FIRE HYDRANT-DETAIL ISPMC SD-404

404-1 INSTALL 1" WATER SERVICE WITH METER PIT INCLUDING METER PER IF SD-401A

404-1.5 INSTALL 1.5" WATER SERVICE WITH METER PIT INCLUDING METER PER IF SD-401A

404-2 INSTALL 2" WATER SERVICE WITH METER PIT INCLUDING METER PER IF SD-401A

SEWER

501-8 INSTALL 8" SDR 35 SANITARY SEWER PIPE @ 0.4% MIN.

501-12 INSTALL 12" SDR 35 SANITARY SEWER PIPE @ 0.4% MIN.

502-1 INSTALL 4" SS MH PER ISPMC SD-501

504-4 INSTALL 4" SDR 35 SANITARY SEWER SERVICE @ 2% MIN SLOPE TO EASEMENT PER IF-511

505-6 INSTALL 6" C-900 PRESSURIZED SANITARY SEWER

506-6.90 INSTALL 6" 90" PRESSURE SEWER BEND WITH THRUST BLOCK PER ISPMC SD - 403

STORM

601-12 INSTALL 12" ADS N 12 STORM PIPE @ 0.22% MIN SLOPE

602-1 INSTALL SD MANHOLE TYPE A WITH REGULAR LID PER F-612

602-2 INSTALL CATCH BASIN TYPE I PER ISPMC SD-601

602-3 INSTALL INFILTRATION MANHOLE PER DETAIL ON SHEET 3

CONCRETE

706-1 INSTALL 6" CURB AND GUTTER PER ISPMC SD-701

706-3 INSTALL 6" CURB AND GUTTER PER CITY OF IDAHO FALLS STANDARD DETAIL IF-701A

706-A1 INSTALL CONCRETE COMMERCIAL APPROACH PER ISPMC SD-710

706-D1 INSTALL CURB DRAIN PER ISPMC SD-715

706-V1 INSTALL VALLEY GUTTER PER IF - 708A

706-S1 INSTALL 4" CONCRETE SIDEWALK PER ISPMC SD-709

706-R1 INSTALL ADA PEDESTRIAN RAMP WITH DETECTABLE WARNING DOMES PER ISPMC SD-712

PRESSURE IRRIGATION

0901.4.1.A.1.04 INSTALL 4" PRESSURIZED IRRIGATION

0901.4.1.A.1.06 INSTALL 6" PRESSURIZED IRRIGATION

0901.4.1.A.1.02 INSTALL 2" PRESSURIZED IRRIGATION







0901.4.1.B.1.90 INSTALL 90" PRESSURIZED IRRIGATION BEND



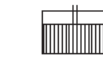













0902.4.1.A.1.01 INSTALL PRESSURIZED IRRIGATION VALVE

TRAFFIC SIGNAL AND STREET LIGHTING

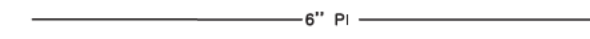

1102-1 INSTALL STREET LIGHT

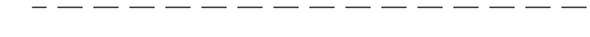
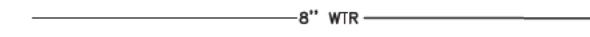
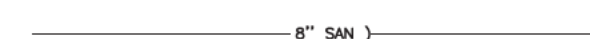









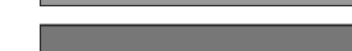



1103-1 INSTALL STOP SIGN AND STREET SIGNS PER MUTCD STD.

-  EXIST. CATCH BASIN
-  EXIST. FIRE HYDRANT
-  EXIST. POWER POLE
-  EXIST. LIGHT POLE
-  EXIST. VALVE
-  EXIST. STORM DRAIN MANHOLE
-  EXIST. SANITARY SEWER MANHOLE

-  BOUNDARY LINE
-  LOT LINE
-  GRADE BREAK
-  SAW CUT
-  STREET RIGHT-OF-WAY (ROW)
-  EASEMENT LINE
-  EXIST. OVERHEAD TELEPHONE
-  CENTERLINE OF ROAD
-  EXIST. GAS SERVICE
-  EXIST. FENCE LINE
-  EXIST. IRRIGATION LINE
-  EXIST. SANITARY SEWER SERVICE
-  EXIST. WATER SERVICE
-  EXIST. WATERLINE
-  EXIST. SANITARY SEWER LINE
-  EXIST. CURB & GUTTER
-  EXIST. UNDERGROUND POWER
-  EXIST. OVERHEAD POWER
-  EXIST. MAJOR CONTOUR
-  EXIST. MINOR CONTOUR

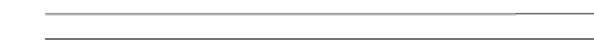
LEGEND

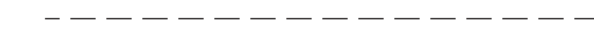
-  PROPOSED CATCH BASIN
-  PROPOSED FIRE HYDRANT
-  PROPOSED POWER POLE
-  PROPOSED STREET LIGHT
-  PROPOSED VALVE
-  PROPOSED STORM DRAIN MANHOLE
-  PROPOSED SANITARY SEWER MANHOLE

-  EXISTING ASPHALT TO BE PROTECTED
-  PROPOSED ASPHALT
-  PROPOSED CONCRETE SIDEWALK
-  PROPOSED BUILDINGS
-  PROPOSED LANDSCAPING
-  PROPOSED FENCE LINE
-  PROPOSED PRESSURE IRRIGATION LINE
-  PROPOSED SANITARY SEWER SERVICE
-  PROPOSED WATER SERVICE
-  PROPOSED WATERLINE
-  PROPOSED SANITARY SEWER LINE
-  PROPOSED FLUSH CURB
-  PROPOSED UNDERGROUND POWER
-  PROPOSED OVERHEAD POWER
-  PROPOSED MAJOR CONTOUR
-  PROPOSED MINOR CONTOUR

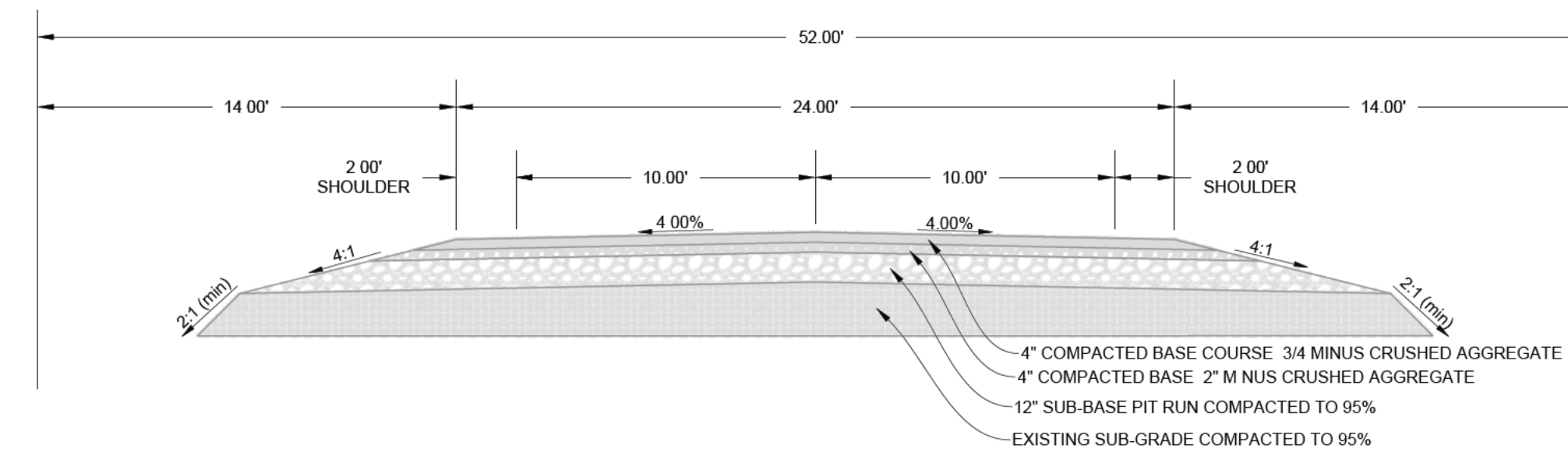

ACRONYMS

- BTM BOTTOM
- FF FINISH FLOOR
- GB GRADE BREAK
- HP HIGH POINT
- LP LOW POINT
- INV IN INVERT N
- INV OUT INVERT OUT
- L LEFT
- R RIGHT
- OFF OFFSET
- PC POINT OF CURVATURE
- PI POINT OF INTERSECTION
- PUD PLANNED UNIT DEVELOPMENT
- PUE PUBLIC UTILITY EASEMENT
- PVI POINT OF VERTICAL INTERSECTION
- CB STORM DRAIN CATCH BASIN
- SDMH STORM DRAIN MANHOLE
- SSMH SANITARY SEWER MANHOLE
- SF SQUARE FEET
- STA STATION
- TBC TOP BACK OF CURB

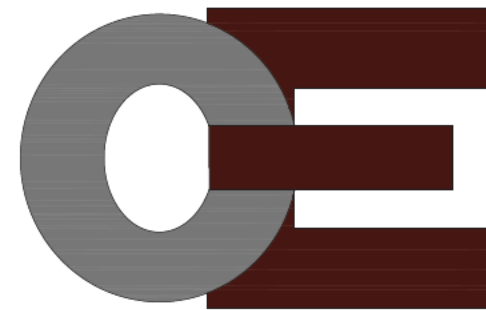

TYPICAL CROSS-SECTION

NOTE:
NOT ALL HATCHES, LINETYPES, REFERENCES, AND SYMBOLS ON THIS SHEET ARE INCLUDED IN THIS PLAN SET.

	DRAWN BY MAK / AQT	CHECK BY BDJ	 Know what's below. Call before you dig.	SHEET NAME: REFERENCE SHEET	ENGINEERS STAMP  PRELIMINARY FOR REVIEW ONLY	SHEET INFORMATION JOB NO: 2021-105	SHEET C-3 14 OF SHEETS
	REVISIONS	DATE		PROJECT: SKYLINE VIEW RANCH		DATE: July 1, 2024	
				LOCATION: TETON COUNTY, ID		SHEET SIZE: 24X36	
						VERTICAL EXAGGERATION: 1V = 10 H	
				PROJECT CONTACT: BARRY BAME CONNECT ENGINEERING 208-861-0081			



GENERAL NOTE:
 ALL PUBLIC IMPROVEMENTS SHALL BE CONSTRUCTED IN ACCORDANCE WITH THE CURRENT CITY OF IDAHO FALLS ENGINEERING STANDARD SPECIFICATIONS AND STANDARD DRAWINGS.

FIRE CODE NOTE:
 D103.6.1 ROADS 20 TO 26 FEET N WIDTH FIRE LANE SIGNS AS SPECIFIED IN SECTION D103.6 SHALL BE POSTED ON BOTH SIDES OF THE FIRE APPARATUS ACCESS ROADS THAT ARE 20 TO 26 FEET W DE (6096 TO 7925 MM)

BASIS OF BEARING
 THE BEARING ALONG THE BOUNDARY LINE BETWEEN SECTIONS 1 AND 12 OF TOWNSHIP 4 NORTH, RANGE 44 EAST, BOISE MERIDIAN, TETON COUNTY, IDAHO IS THE BASIS FOR ALL BEARINGS

BENCHMARK
 STATIC GPS SURVEY ON A 5/8" IRON ROD PLS NO CAP BEING THE NORTHEAST CORNER SECTION 12, INSTRUMENT# 126786 DATA CORRECTED THROUGH ONLINE POSITIONING USER SERVICE (OPUS) REF FRAME: NAD_83(2011)(EPOCH 2010.0000) ORTHOMETRIC HEIGHT: NAVD88 [COMPUTED USING GEOID12B]

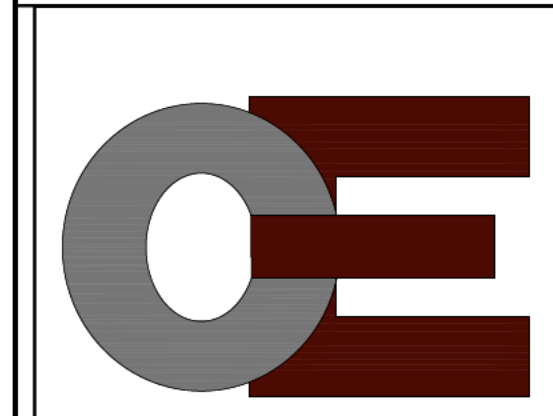

DRAWN BY	CHECK BY
MAK / AQT	BDJ
REVISIONS	DATE

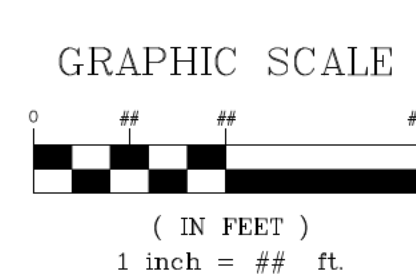
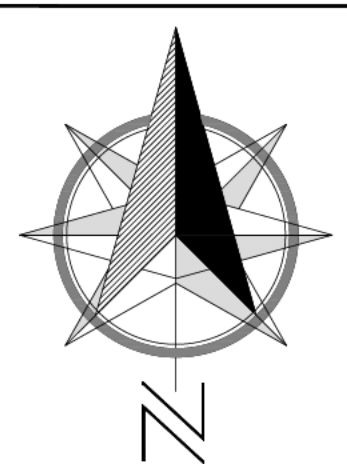

SHEET NAME:	EXISTING CONDITIONS
PROJECT:	SKYLINE VIEW RANCH
LOCATION:	TETON COUNTY, ID

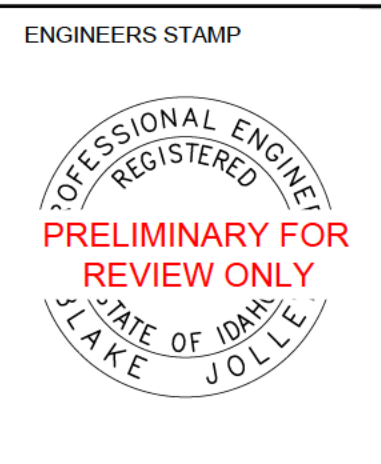

SHEET INFORMATION
JOB NO: 2021-105
DATE: July 1, 2024
SHEET SIZE: 24X36
VERTICAL EXAGGERATION: VERT. EXAGGERATION
PROJECT CONTACT: BARRY BAME, CONNECT ENGINEERING, 208-881-0881

SHEET	14	SHEET NUMBER
OF		SHEETS



ALL LOTS TO BE SERVICED BY PRIVATE WELL AND SEPTIC. SEPTIC SYSTEMS TO BE NO GREATER THAT 600 GALLONS PER DAY

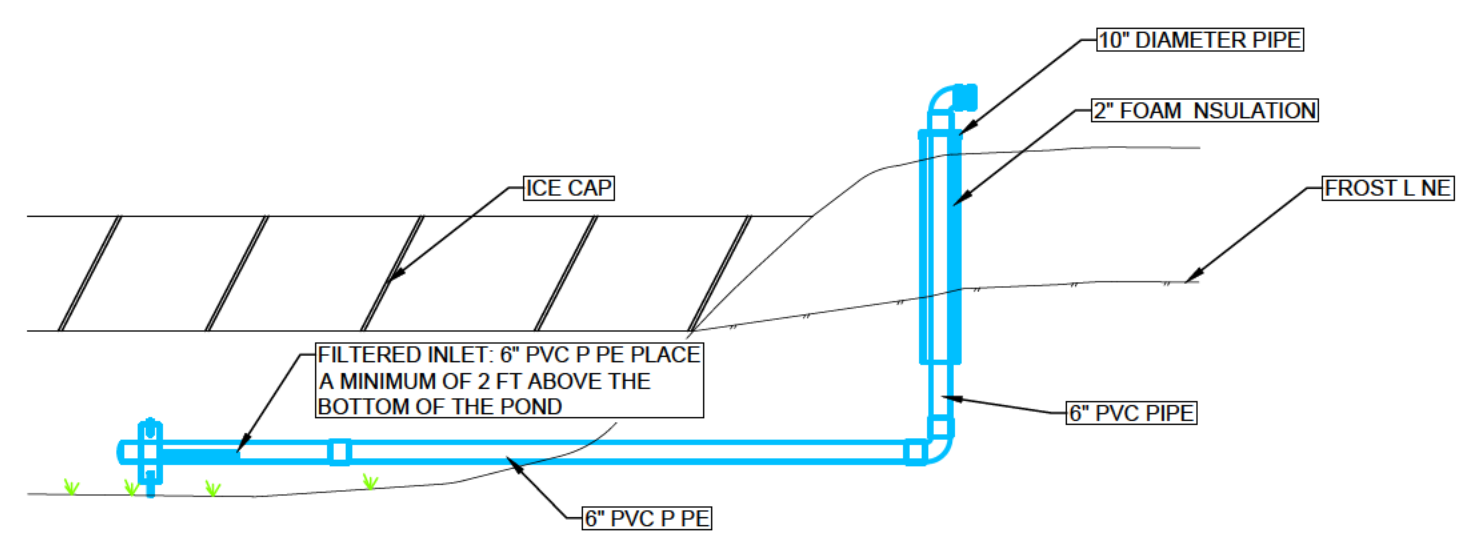
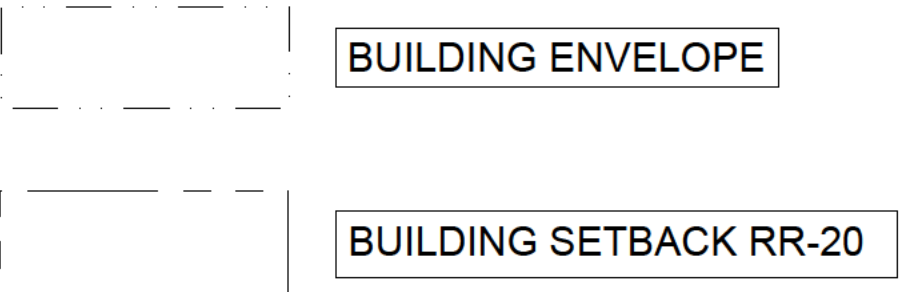

EXAMPLE FREEZE PROTECTION FOR DRY HYDRANT AT FIRE POND NTS

	DRAWN BY MAK / AGT	CHECK BY BDJ	 N Z	 GRAPHIC SCALE (IN FEET) 1 inch = ## ft.	 Know what's below. Call before you dig.	SHEET NAME: SITE PLAN		SHEET INFORMATION	SURVEY NOTE: This site plan conforms to an actual survey that was performed on the ground by a licensed land surveyor in and for the State of Idaho. It is the owner's responsibility to construct all structures shown on this site plan in accordance with said survey.	SHEET C-5 14 OF SHEETS
	REVISIONS	DATE				PROJECT: SKYLINE VIEW RANCH		JOB NO: 2021-105 DATE: July 1, 2024 SHEET SIZE: 24X36 VERTICAL EXAGGERATION: 1V = 10 H PROJECT CONTACT: BARRY BAME CONNECT ENGINEERING 208-881-0881		
						LOCATION: TETON COUNTY, ID				

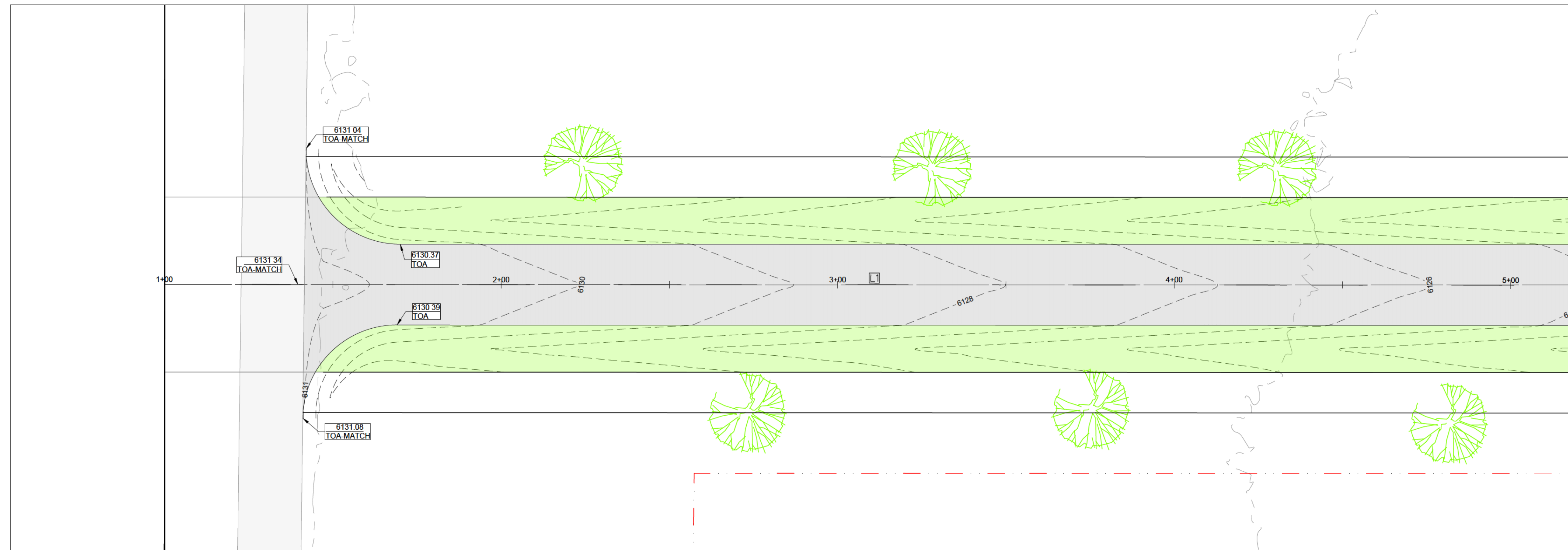

PRIVATE RD - CADDIS DR S-N STA: 1+00 to 5+00 - PLAN VIEW

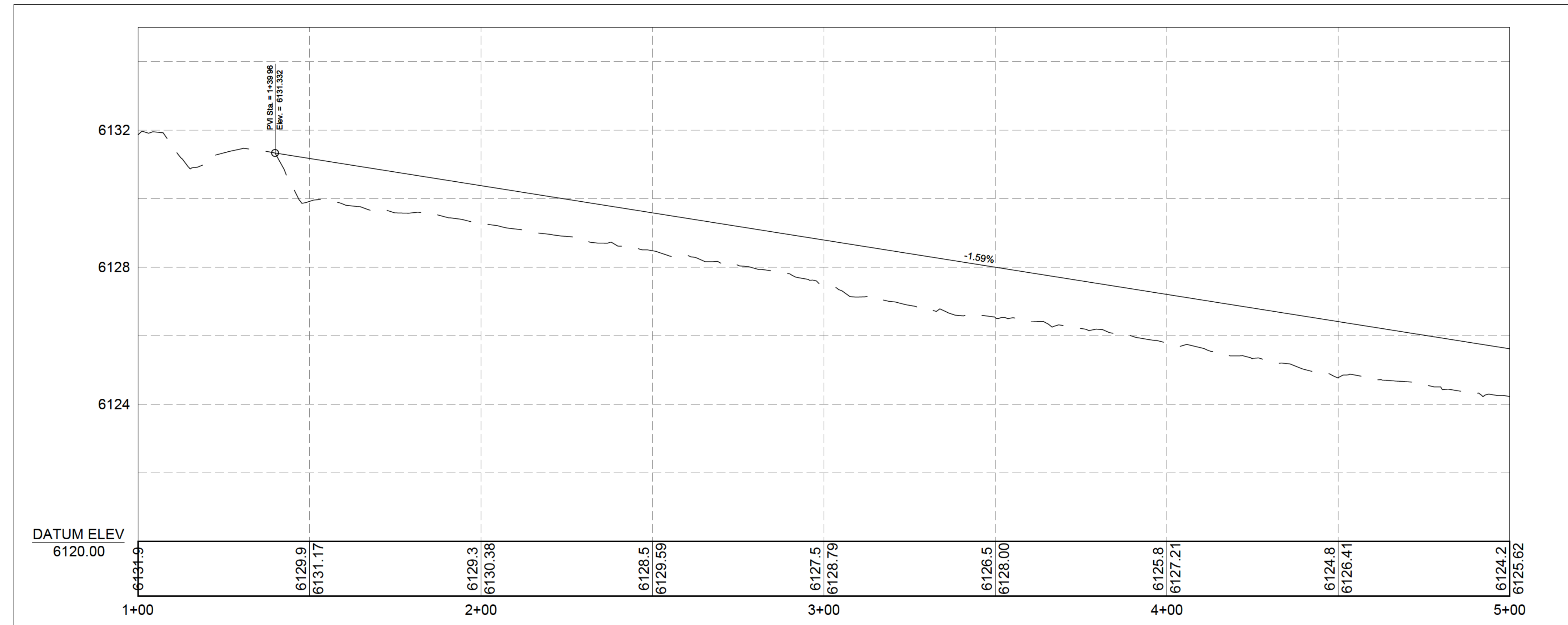

PRIVATE RD - CADDIS DR S-N STA: 1+00 to 5+00 - PROFILE VIEW

- SEE SHEET 3 FOR MORE INFORMATION
- 100-T RETAIN AND PROTECT
 - 200-T SAW CUT AND ASPHALT REMOVAL
 - 401.6 6" WATER MAIN
 - 401.6.90 6" 90° WATER BEND
 - 401.6.45 6" 45° WATER BEND
 - 401.6.6 6"X6"X6" TEE
 - 401.6.4 6"X6"X4" TEE
 - 402.6 6" WATER MAIN VALVE
 - 403.1 FIRE HYDRANT ASSEMBLY
 - 404.4 4" WATER SERVICE
- SEE SHEET 3 FOR MORE INFORMATION

- NOTE:
1. CONTRACTOR TO VERIFY ALL EXISTING UTILITY LOCATIONS AND COORDINATE WITH EACH UTILITY COMPANY. PRIOR TO CONNECTING ANY PROPOSED UTILITIES.
 2. ENSURE 10' MINIMUM HORIZONTAL CLEARANCE BETWEEN ALL POTABLE AND NON-POTABLE LINES ARE MET PER IDEQ AND CITY OF IDAHO FALLS STANDARDS. F MANHOLES ARE IN AN ASPHALT PAVED AREA THE COLLARS ARE TO BE ASPHALT COLLARS
 3. ENSURE 18" MINIMUM VERTICAL CLEARANCE BETWEEN ALL POTABLE AND NON-POTABLE LINES ARE MET PER IDEQ AND CITY OF IDAHO FALLS STANDARDS
 4. ASSUMED TOP OF FOUNDATION WALL IS FINISHED FLOOR, CONTRACTOR TO NOTIFY ENGINEER IF DIFFERENT.

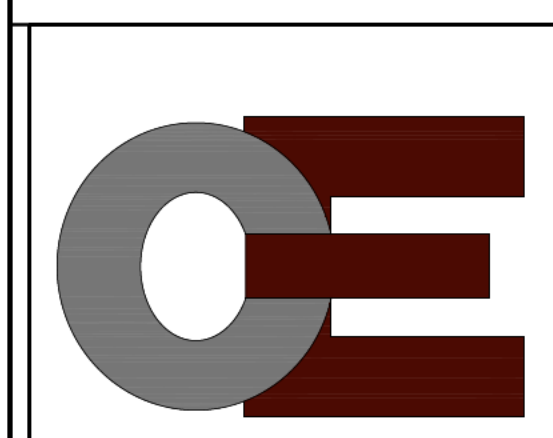

DRAWN BY	CHECK BY
MAK / AQT	BDJ
REVISIONS	DATE

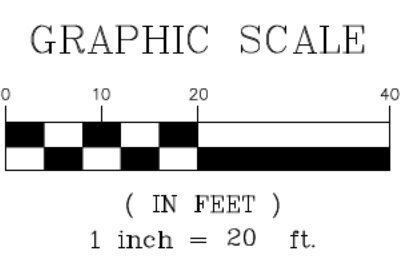

SHEET NAME: CADDIS RD STA. 1+00 TO 5+00

PROJECT: SKYLINE VIEW RANCH

LOCATION: TETON COUNTY, ID

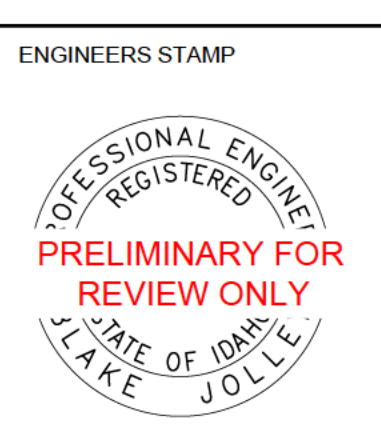

SHEET INFORMATION	
JOB NO:	2021-105
DATE:	July 1, 2024
SHEET SIZE:	24X36
VERTICAL EXAGGERATION: 1V = 10 H	
PROJECT CONTACT: BARRY BAME CONNECT ENGINEERING 208-881-0061	

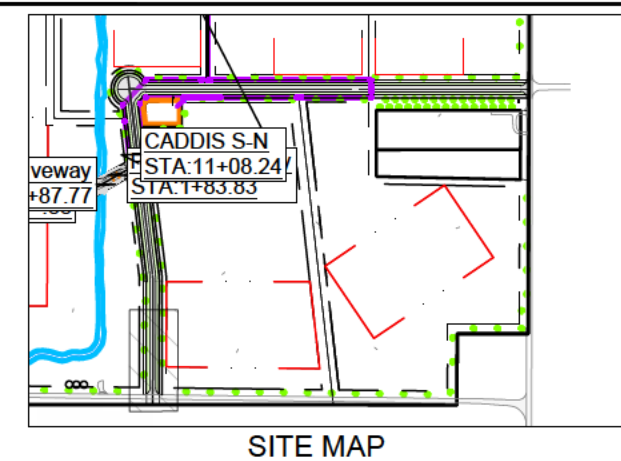

SHEET C-6
OF 14 SHEETS

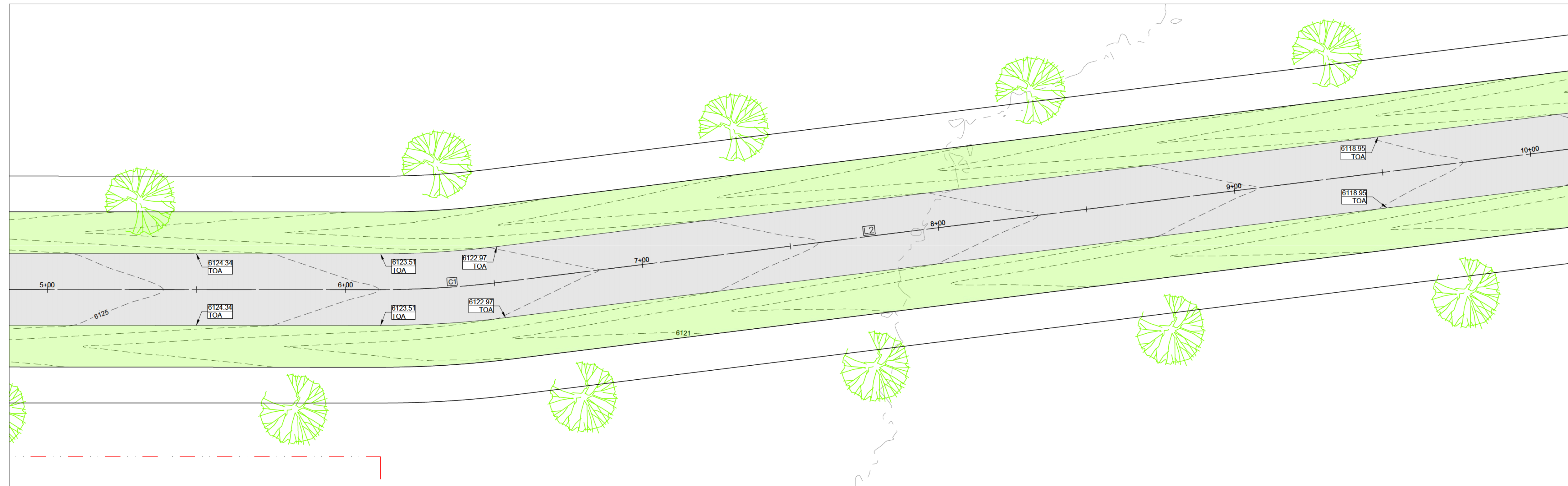

- SEE SHEET 3 FOR MORE INFORMATION
- 100-1 RETAIN AND PROTECT
 - 200-1 SAW CUT AND ASPHALT REMOVAL
 - 401-6 6" WATER MAIN
 - 401-6-90 6" 90° WATER BEND
 - 401-6-45 6" 45° WATER BEND
 - 401-6-6-6 6"X6"X6" TEE
 - 401-6-6-4 6"X6"X4" TEE
 - 402-6 6" WATER MAIN VALVE
 - 403-1 FIRE HYDRANT ASSEMBLY
 - 404-4 4" WATER SERVICE
- SEE SHEET 3 FOR MORE INFORMATION

PRIVATE RD - CADDIS DR S-N STA: 5+00 to 10+00 - PLAN VIEW

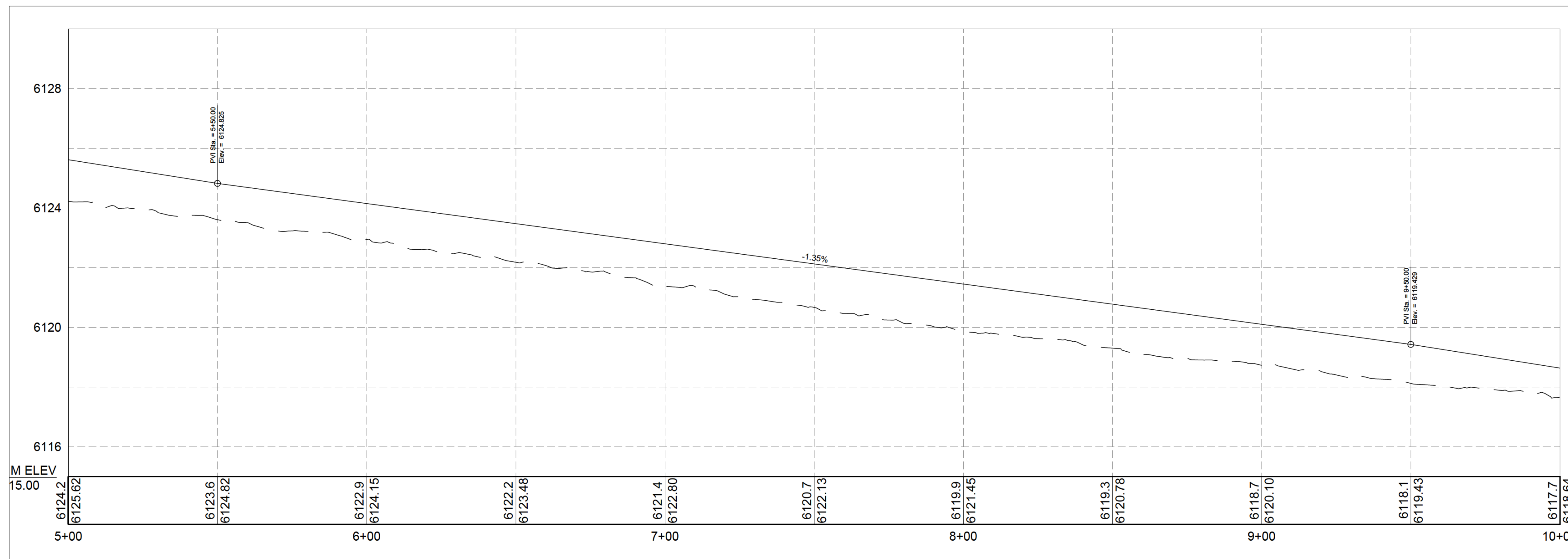

- NOTE:
1. CONTRACTOR TO VERIFY ALL EXISTING UTILITY LOCATIONS AND COORDINATE WITH EACH UTILITY COMPANY. PRIOR TO CONNECTING ANY PROPOSED UTILITIES.
 2. ENSURE 10' MINIMUM HORIZONTAL CLEARANCE BETWEEN ALL POTABLE AND NON-POTABLE LINES ARE MET PER IDEQ AND CITY OF IDAHO FALLS STANDARDS. F MANHOLES ARE IN AN ASPHALT PAVED AREA THE COLLARS ARE TO BE ASPHALT COLLARS ENSURE 18" MINIMUM VERTICAL CLEARANCE BETWEEN ALL POTABLE AND NON-POTABLE LINES ARE MET PER IDEQ AND CITY OF IDAHO FALLS STANDARDS.
 3. ENSURE 18" MINIMUM VERTICAL CLEARANCE BETWEEN ALL POTABLE AND NON-POTABLE LINES ARE MET PER IDEQ AND CITY OF IDAHO FALLS STANDARDS.
 4. ASSUMED TOP OF FOUNDATION WALL IS FINISHED FLOOR, CONTRACTOR TO NOTIFY ENGINEER IF DIFFERENT.

PRIVATE RD - CADDIS DR S-N STA: 5+00 to 10+00 - PROFILE VIEW

	DRAWN BY MAK / AQT	CHECK BY BDJ		<p>GRAPHIC SCALE</p> <p>(IN FEET) 1 inch = 20 ft.</p>		SHEET NAME: CADDIS RD STA. 5+00 TO 10+00		ENGINEERS STAMP	SHEET INFORMATION	<p>SITE MAP</p>	C-7 14	SHEET OF SHEETS
	REVISIONS	DATE				PROJECT: SKYLINE VIEW RANCH		JOB NO: 2021-105	DATE: July 1, 2024			
LOCATION: TETON COUNTY, ID												

- SEE SHEET 3 FOR MORE INFORMATION
- 100-1 RETAIN AND PROTECT
 - 200-1 SAW CUT AND ASPHALT REMOVAL
 - 401-6 6" WATER MAIN
 - 401-6.90 6" 90° WATER BEND
 - 401-6.45 6" 45° WATER BEND
 - 401-6.6.6 6"X6"X6" TEE
 - 401-6.6.4 6"X6"X4" TEE
 - 402-6 6" WATER MAIN VALVE
 - 403-1 FIRE HYDRANT ASSEMBLY
 - 404-4 4" WATER SERVICE
- SEE SHEET 3 FOR MORE INFORMATION

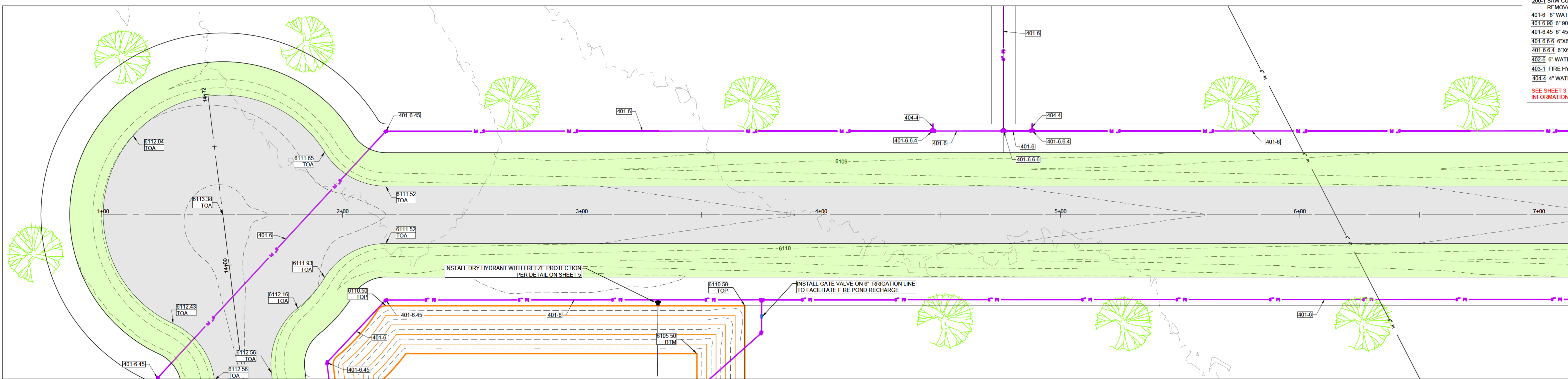

PRIVATE RD - CADDIS W-E STA: 1+00 to 7+00 - PLAN VIEW

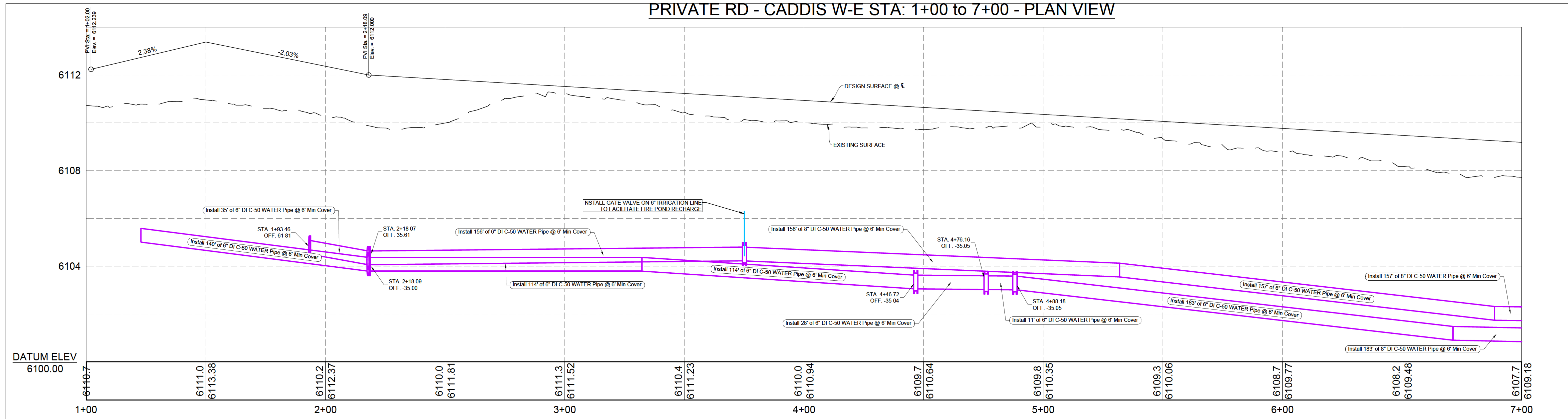

PRIVATE RD - CADDIS DR W-E STA: 1+00 to 7+00 - PROFILE VIEW

- NOTE:
1. CONTRACTOR TO VERIFY ALL EXISTING UTILITY LOCATIONS AND COORDINATE WITH EACH UTILITY COMPANY PRIOR TO CONNECTING ANY PROPOSED UTILITIES.
 2. ENSURE 10' MINIMUM HORIZONTAL CLEARANCE BETWEEN ALL POTABLE AND NON-POTABLE LINES ARE MET PER IDEQ AND CITY OF DAHO FALLS STANDARDS. IF MANHOLES ARE IN AN ASPHALT PAVED AREA THE COLLARS ARE TO BE ASPHALT COLLARS.
 3. ENSURE 18" MINIMUM VERTICAL CLEARANCE BETWEEN ALL POTABLE AND NON-POTABLE LINES ARE MET PER IDEQ AND CITY OF DAHO FALLS STANDARDS.
 4. ASSUMED TOP OF FOUNDATION WALL IS FINISHED FLOOR, CONTRACTOR TO NOTIFY ENGINEER IF DIFFERENT.

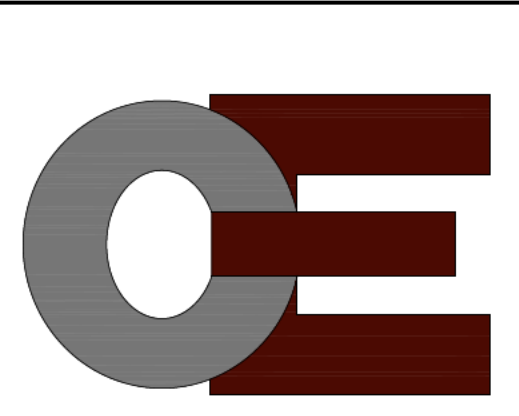

DRAWN BY	CHECK BY
MAK / AQT	BDJ
REVISIONS	DATE

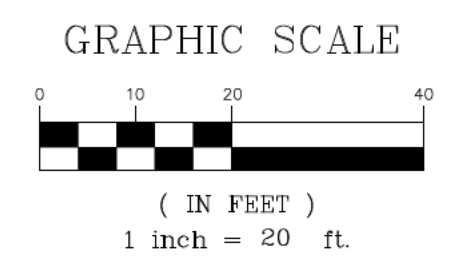

SHEET NAME:	CADDIS RD STA. 1+00 TO 7+00
PROJECT:	SKYLINE VIEW RANCH
LOCATION:	TETON COUNTY, ID

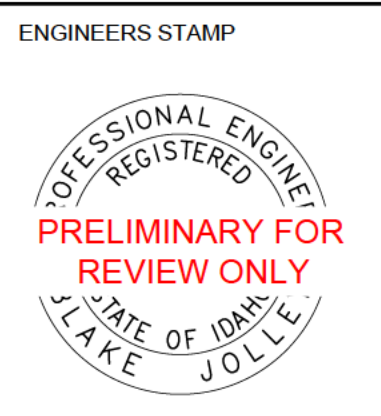

ENGINEERS STAMP	SHEET INFORMATION
	JOB NO: 2021-105
	DATE: July 1, 2024
	SHEET SIZE: 24X36
	VERTICAL EXAGGERATION: 1V = 10 H
	PROJECT CONTACT: BARRY BAME, CONNECT ENGINEERING, 208-881-0061

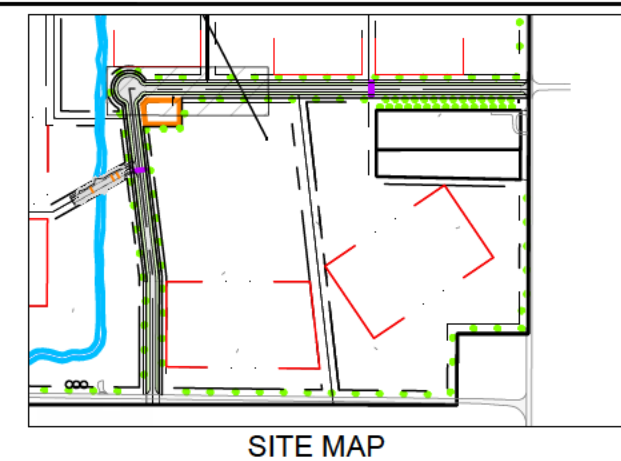

SHEET	C-9
OF	14
SHEETS	

- SEE SHEET 3 FOR MORE INFORMATION
- 100-T RETAIN AND PROTECT
 - 200-T SAW CUT AND ASPHALT REMOVAL
 - 401-6 6" WATER MAIN
 - 401-6 90° 6" 90° WATER BEND
 - 401-6 45° 6" 45° WATER BEND
 - 401-6 6.6 6"X6"X6" TEE
 - 401-6 6.4 6"X6"X4" TEE
 - 402-6 6" WATER MAIN VALVE
 - 403-T FIRE HYDRANT ASSEMBLY
 - 404-T 4" WATER SERVICE
- SEE SHEET 3 FOR MORE INFORMATION

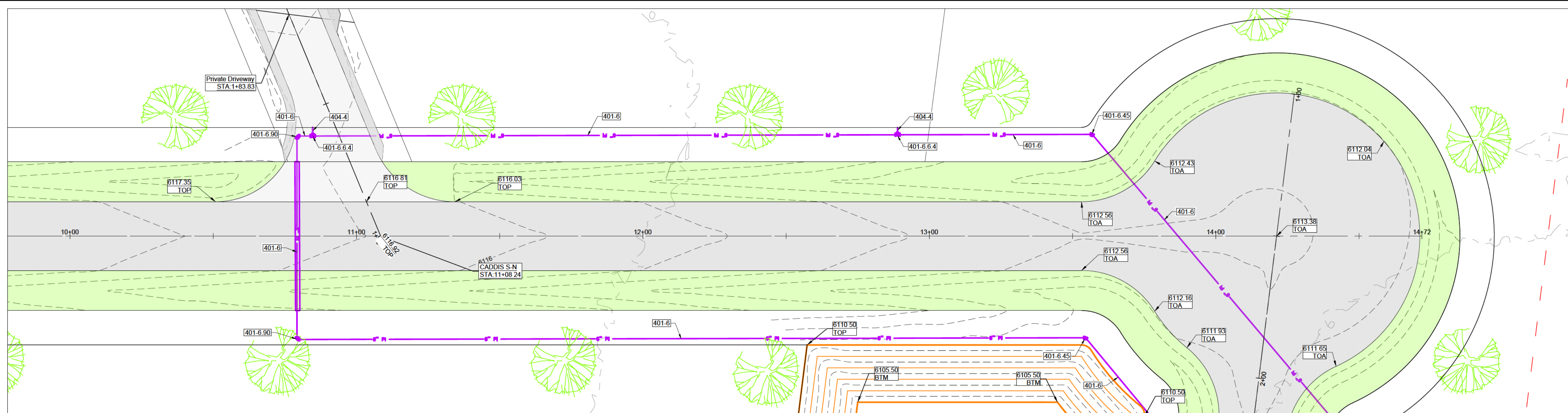

PRIVATE RD - CADDIS DR S-N STA: 10+00 to 14+72 - PLAN VIEW

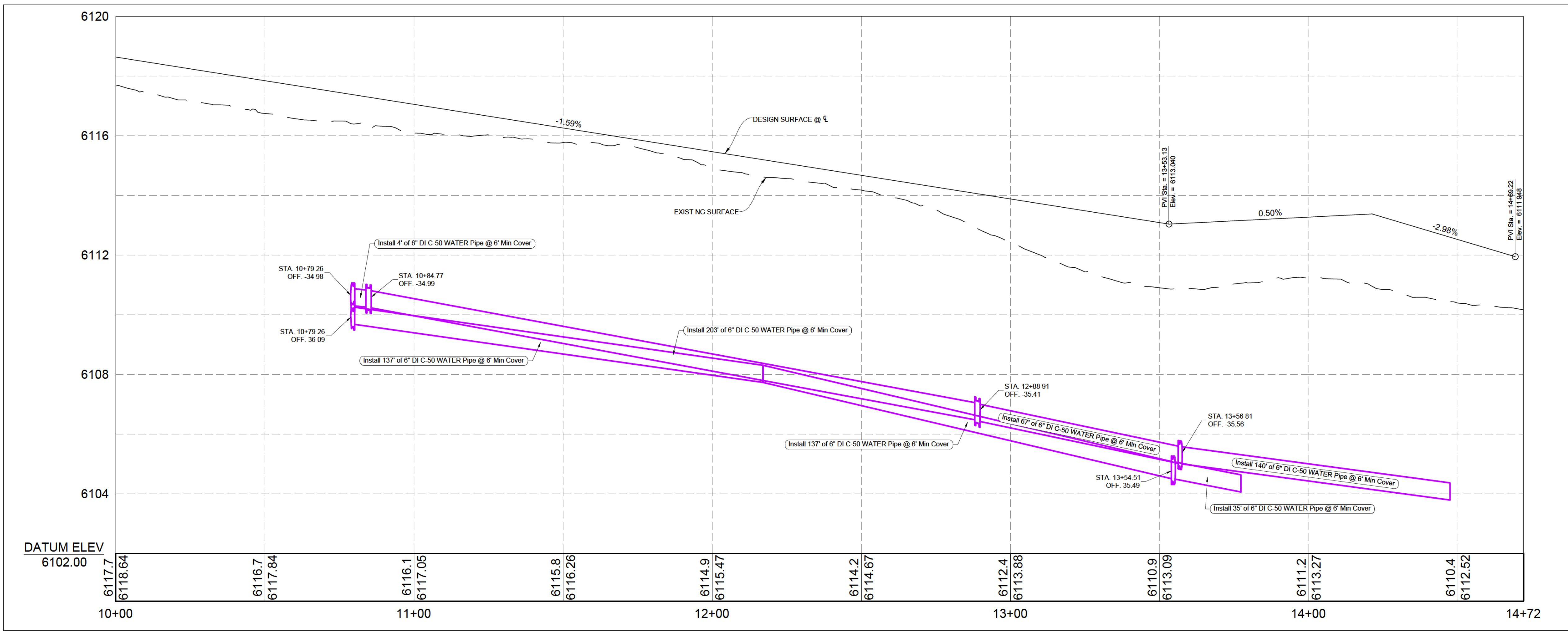

PRIVATE RD - CADDIS DR S-N STA: 10+00 to 14+72 - PROFILE VIEW

- NOTE:
1. CONTRACTOR TO VERIFY ALL EXISTING UTILITY LOCATIONS AND COORDINATE WITH EACH UTILITY COMPANY. PRIOR TO CONNECTING ANY PROPOSED UTILITIES.
 2. ENSURE 10' MINIMUM HORIZONTAL CLEARANCE BETWEEN ALL POTABLE AND NON-POTABLE LINES ARE MET PER IDEQ AND CITY OF IDAHO FALLS STANDARDS. F MANHOLES ARE IN AN ASPHALT PAVED AREA THE COLLARS ARE TO BE ASPHALT COLLARS
 3. ENSURE 18" MINIMUM VERTICAL CLEARANCE BETWEEN ALL POTABLE AND NON-POTABLE LINES ARE MET PER IDEQ AND CITY OF IDAHO FALLS STANDARDS
 4. ASSUMED TOP OF FOUNDATION WALL IS FINISHED FLOOR, CONTRACTOR TO NOTIFY ENGINEER IF DIFFERENT.

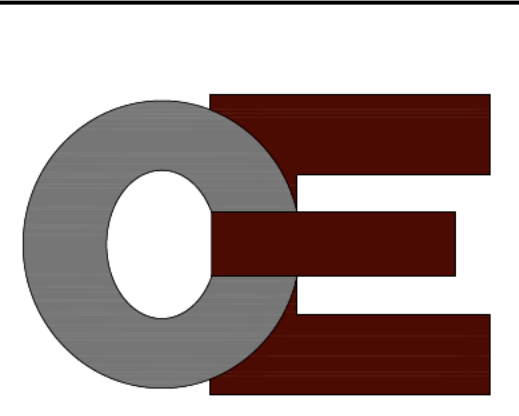

DRAWN BY	CHECK BY
MAK / AQT	BDJ
REVISIONS	DATE

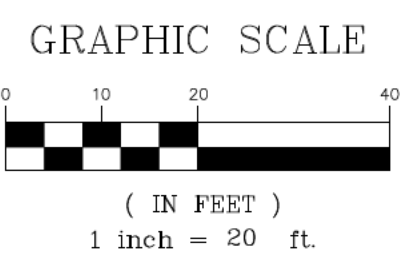
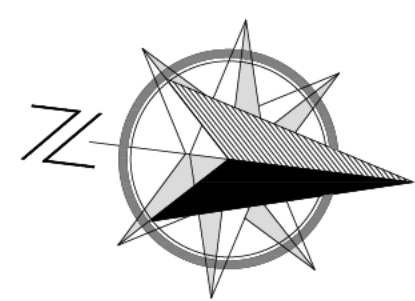

SHEET NAME: CADDIS RD STA. 10+00 TO 14+72

PROJECT: SKYLINE VIEW RANCH

LOCATION: TETON COUNTY, ID

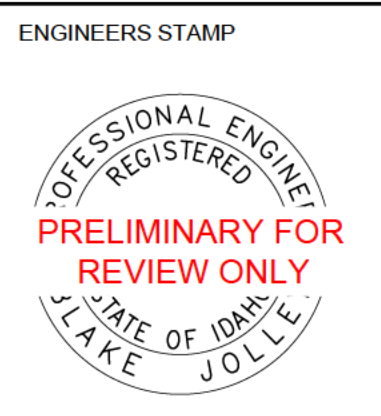

ENGINEERS STAMP
SHEET INFORMATION
JOB NO: 2021-105
DATE: July 1, 2024
SHEET SIZE: 24X36
VERTICAL EXAGGERATION: 1V = 10 H
PROJECT CONTACT: BARRY BAME, CONNECT ENGINEERING, 208-881-0061

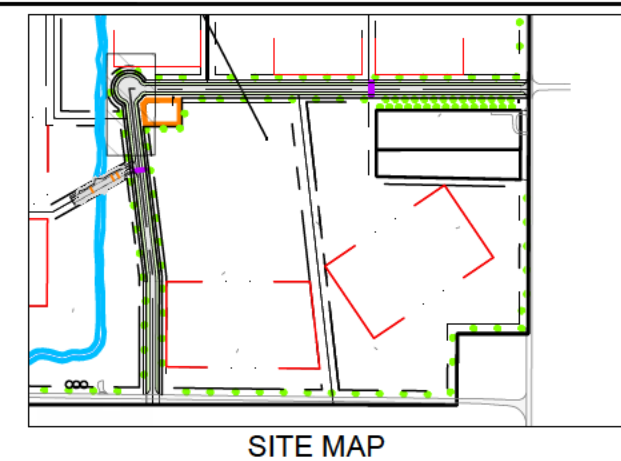

SHEET C-8 OF 14 SHEETS

SEE SHEET 3 FOR MORE INFORMATION

100-1 RETAIN AND PROTECT
 200-1 SAW CUT AND ASPHALT REMOVAL
 401-6 6" WATER MAIN
 401-6.90 6" 90° WATER BEND
 401-6.45 6" 45° WATER BEND
 401-6.6.6 6"X6"X6" TEE
 401-6.6.4 6"X6"X4" TEE
 402-6 6" WATER MAIN VALVE
 403-1 FIRE HYDRANT ASSEMBLY
 404-4 4" WATER SERVICE

SEE SHEET 3 FOR MORE INFORMATION

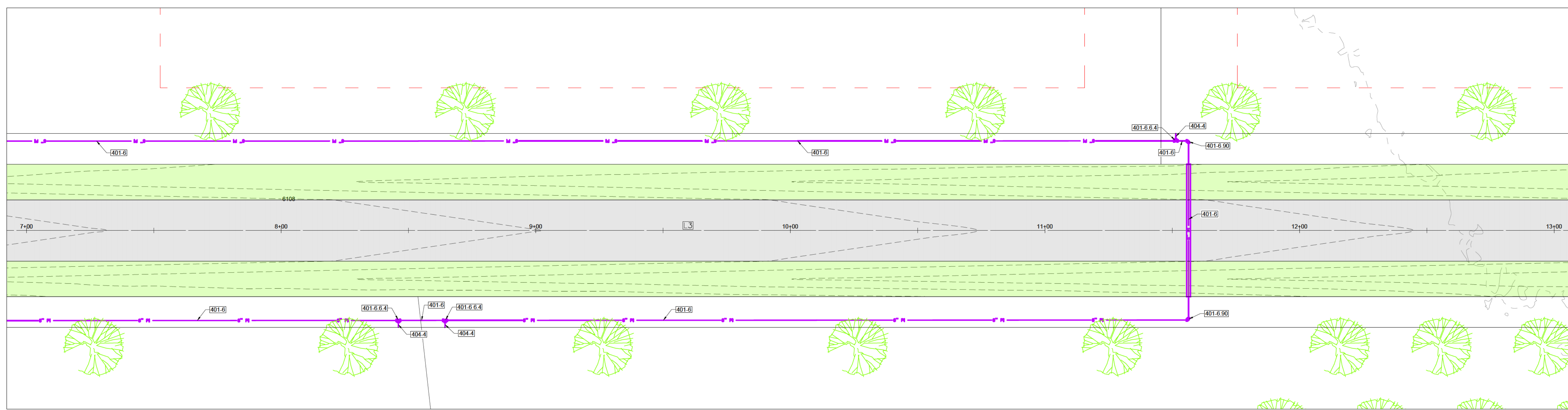

PRIVATE RD - CADDIS DR W-E STA: 7+00 to 13+00 - PLAN VIEW

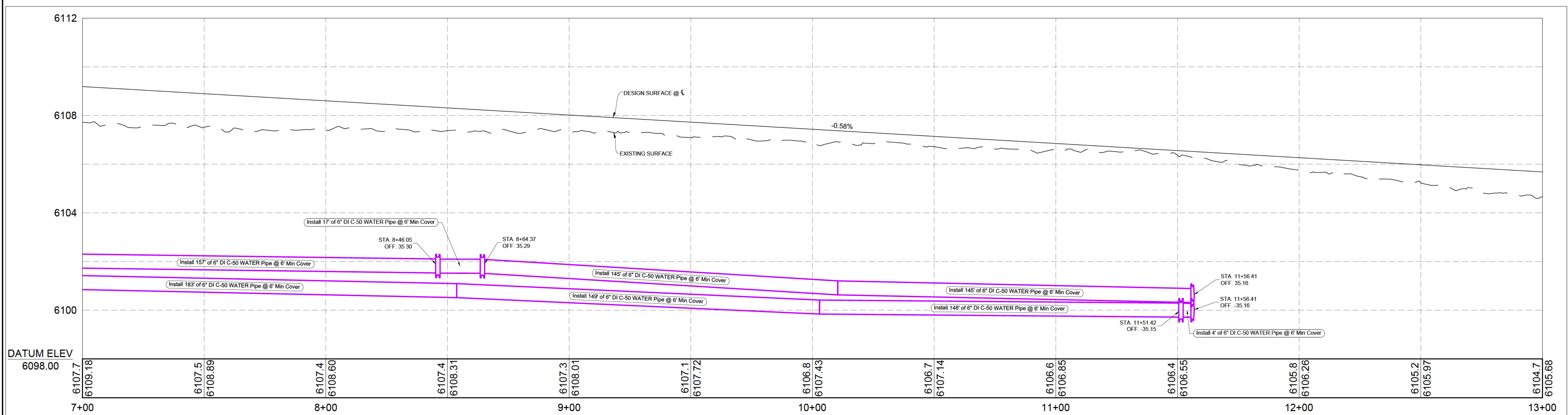

PRIVATE RD - CADDIS DR W-E STA: 7+00 to 13+00 - PROFILE VIEW

- NOTE:
- CONTRACTOR TO VERIFY ALL EXISTING UTILITY LOCATIONS AND COORDINATE WITH EACH UTILITY COMPANY. PRIOR TO CONNECTING ANY PROPOSED UTILITIES.
 - ENSURE 18" MINIMUM HORIZONTAL CLEARANCE BETWEEN ALL POTABLE AND NON-POTABLE LINES ARE MET PER DEQ AND CITY OF IDAHO FALLS STANDARDS. IF MANHOLES ARE IN AN ASPHALT PAVED AREA THE COLLARS ARE TO BE ASPHALT COLLARS.
 - ENSURE 18" MINIMUM VERTICAL CLEARANCE BETWEEN ALL POTABLE AND NON-POTABLE LINES ARE MET PER DEQ AND CITY OF IDAHO FALLS STANDARDS.
 - ASSUMED TOP OF FOUNDATION WALL IS FINISHED FLOOR, CONTRACTOR TO NOTIFY ENGINEER IF DIFFERENT.

DRAWN BY MAK / AQT	CHECK BY BDJ
	DATE
REVISIONS	DATE

GRAPHIC SCALE
 0 10 20 40
 (IN FEET)
 1 inch = 20 ft.

SHEET NAME:
CADDIS RD STA. 7+00 TO 13+00

PROJECT:
SKYLINE VIEW RANCH

LOCATION:
TETON COUNTY, ID

ENGINEERS STAMP	SHEET INFORMATION
	JOB NO: 2021-105
	DATE: July 1, 2024
	SHEET SIZE: 24X36
	VERTICAL EXAGGERATION: 1V = 10 H
PROJECT CONTACT: BARRY BAME CONNECT ENGINEERING 208-881-0061	

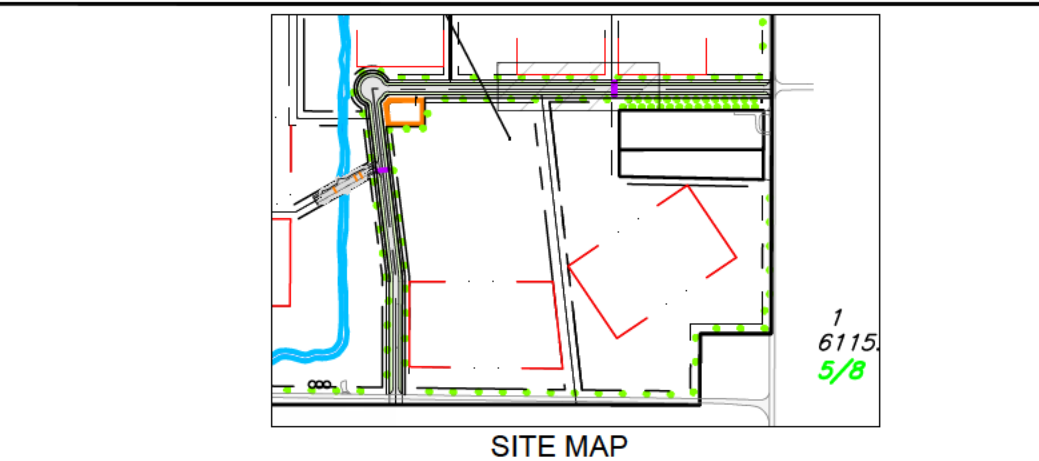

SHEET
C-10
14
 OF SHEETS

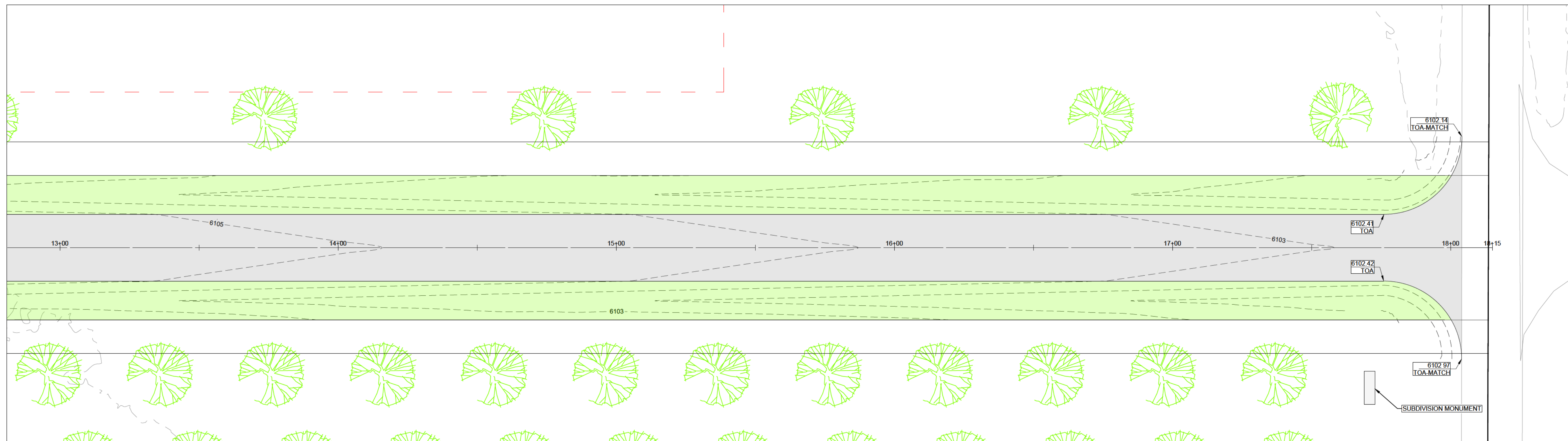

- SEE SHEET 3 FOR MORE INFORMATION
- 100-T RETAIN AND PROTECT
 - 200-T SAW CUT AND ASPHALT REMOVAL
 - 401.6 6" WATER MAIN
 - 401.6.90 6" 90° WATER BEND
 - 401.6.45 6" 45° WATER BEND
 - 401.6.6 6" X6" X6" TEE
 - 401.6.6.4 6" X6" X4" TEE
 - 402.6 6" WATER MAIN VALVE
 - 403.1 FIRE HYDRANT ASSEMBLY
 - 404.4 4" WATER SERVICE
- SEE SHEET 3 FOR MORE INFORMATION

PRIVATE RD - CADDIS DR W-E STA: 13+00 to 18+14 - PLAN VIEW

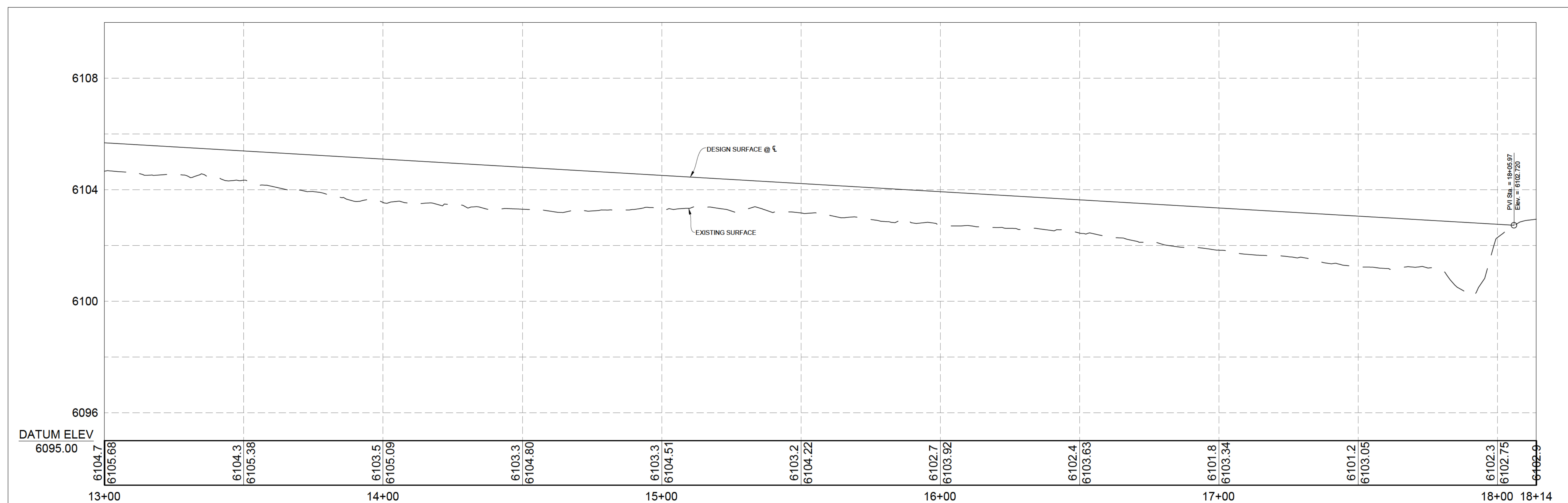

PRIVATE RD - CADDIS DR W-E STA: 13+00 to 18+14 - PROFILE VIEW

- NOTE:
1. CONTRACTOR TO VERIFY ALL EXISTING UTILITY LOCATIONS AND COORDINATE WITH EACH UTILITY COMPANY. PRIOR TO CONNECTING ANY PROPOSED UTILITIES.
 2. ENSURE 10' MINIMUM HORIZONTAL CLEARANCE BETWEEN ALL POTABLE AND NON-POTABLE LINES ARE MET PER IDEQ AND CITY OF IDAHO FALLS STANDARDS. FIRE MANHOLES ARE IN AN ASPHALT PAVED AREA THE COLLARS ARE TO BE ASPHALT COLLARS.
 3. ENSURE 18" MINIMUM VERTICAL CLEARANCE BETWEEN ALL POTABLE AND NON-POTABLE LINES ARE MET PER IDEQ AND CITY OF IDAHO FALLS STANDARDS.
 4. ASSUMED TOP OF FOUNDATION WALL IS FINISHED FLOOR, CONTRACTOR TO NOTIFY ENGINEER IF DIFFERENT.

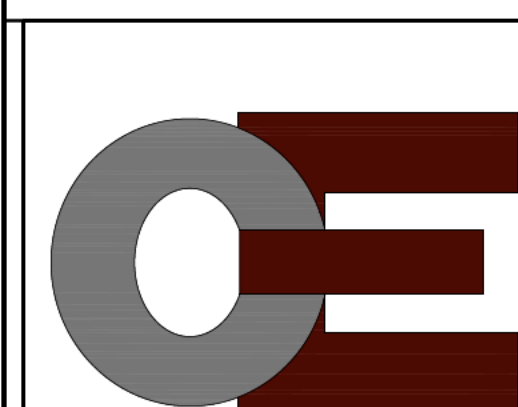

DRAWN BY	CHECK BY
MAK / AQT	BDJ
REVISIONS	DATE

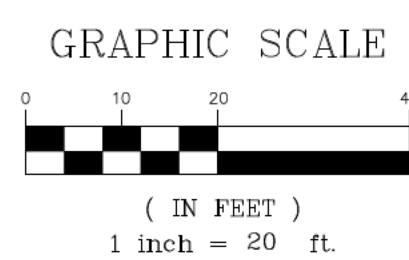
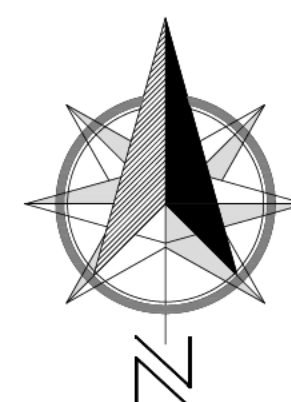

SHEET NAME:	CADDIS RD STA. 13+00 TO 18+14
PROJECT:	SKYLINE VIEW RANCH
LOCATION:	TETON COUNTY, ID

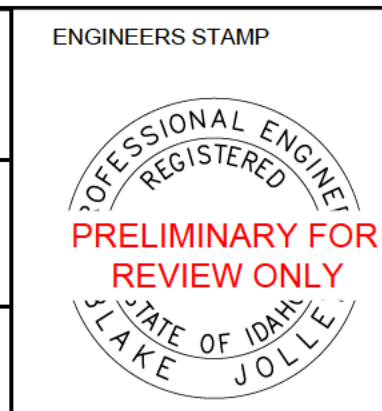

SHEET INFORMATION
JOB NO: 2021-105
DATE: July 1, 2024
SHEET SIZE: 24X36
VERTICAL EXAGGERATION: 1V = 10 H
PROJECT CONTACT:
BARRY BAME
CONNECT ENGINEERING
208-881-0061

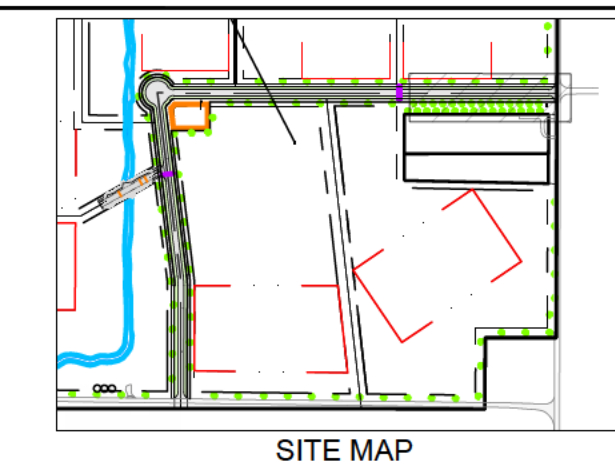

SHEET	C-11
OF	14
SHEETS	

- NOTE:**
- CONTRACTOR TO VERIFY ALL EXISTING UTILITY LOCATIONS AND COORDINATE WITH EACH UTILITY COMPANY. PRIOR TO CONNECTING ANY PROPOSED UTILITIES.
 - ENSURE 10' MINIMUM HORIZONTAL CLEARANCE BETWEEN ALL POTABLE AND NON-POTABLE LINES ARE MET PER IDEQ AND CITY OF IDAHO FALLS STANDARDS. IF MANHOLES ARE IN AN ASPHALT PAVED AREA THE COLLARS ARE TO BE ASPHALT COLLARS
 - ENSURE 18" MINIMUM VERTICAL CLEARANCE BETWEEN ALL POTABLE AND NON-POTABLE LINES ARE MET PER IDEQ AND CITY OF IDAHO FALLS STANDARDS.
 - ASSUMED TOP OF FOUNDATION WALL IS FINISHED FLOOR. CONTRACTOR TO NOTIFY ENGINEER IF DIFFERENT.

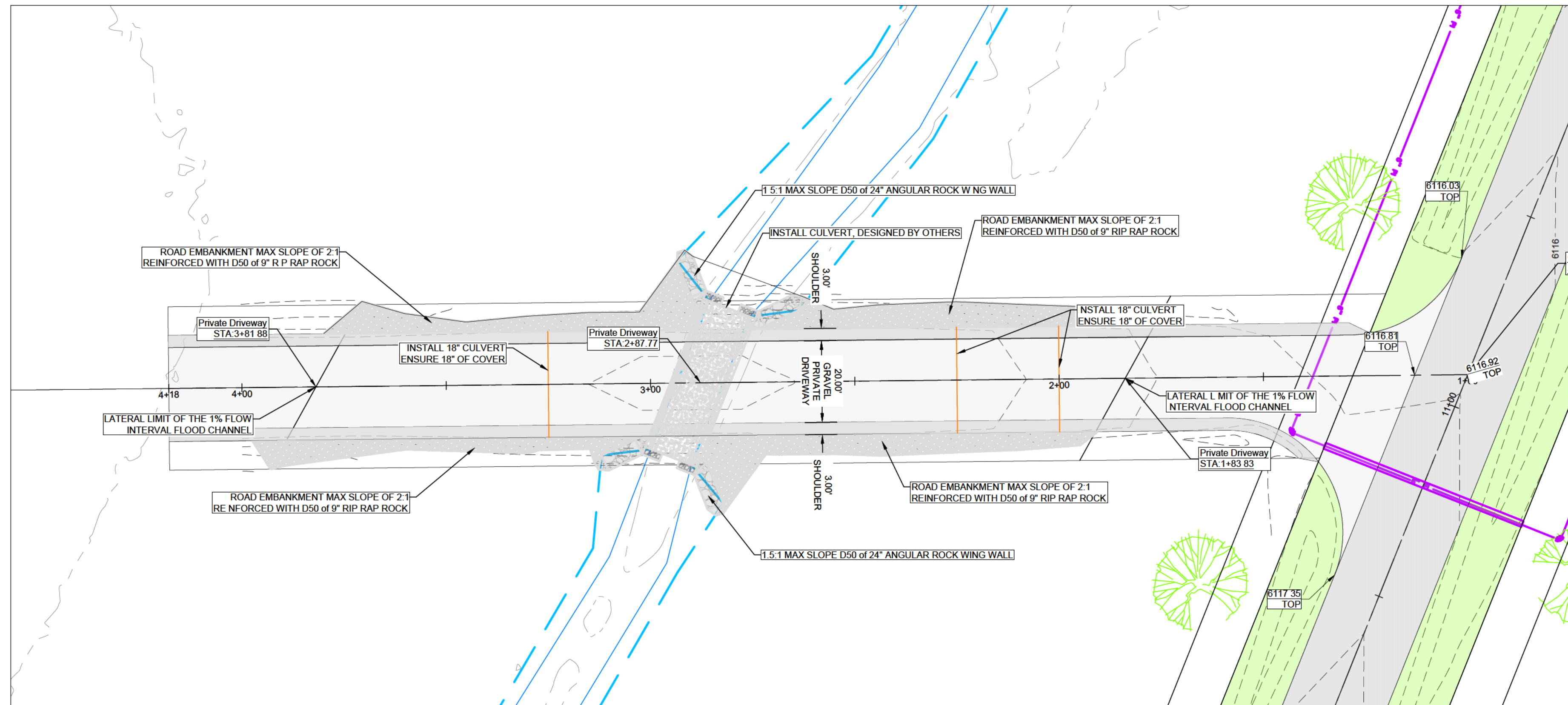

PRIVATE RD - CADDIS DR S-N STA: 1+00 to 5+00 - PLAN VIEW

1% AEP FLOOD - DESIGN REQUIREMENT

Flow, Q = 479 cfs

PROPOSED CULVERT DESIGN

Manning's Formula: $Q=VA$

- Width, W = 10.65 ft
- Depth, y = 2.5 ft
- Slope, S = 0.0115
- Manning roughness, n = 0.018
- Flow area, A = 31.95 ft²
- Wetted perimeter, Pw = 16.65 ft
- Hydraulic radius, Rh = 1.92 ft
- Velocity, v = 13.67 ft/sec
- Flow, Q = 436.76 cfs

Three 18" supplemental culverts with a capacity of 17.71 cfs will be placed under the private drive to accommodate the remaining 100 year event flows.

Total Q = 490 cfs

EXISTING CHANNEL MAX CAPACITY @ CROSSING LOCATION

Manning's Formula: $Q=VA$

- BOTTOM Width, W = 15.15 ft
- SIDE SLOPES = 2:1
- Depth, y = 2.81 ft
- Slope, S = 0.0115
- Manning roughness, n = 0.035
- Flow area, A = 58.36 ft²
- Wetted perimeter, Pw = 27.71 ft
- Hydraulic radius, Rh = 2.10 ft
- Velocity, v = 7.48 ft/sec
- Flow, Q = 436.53 cfs

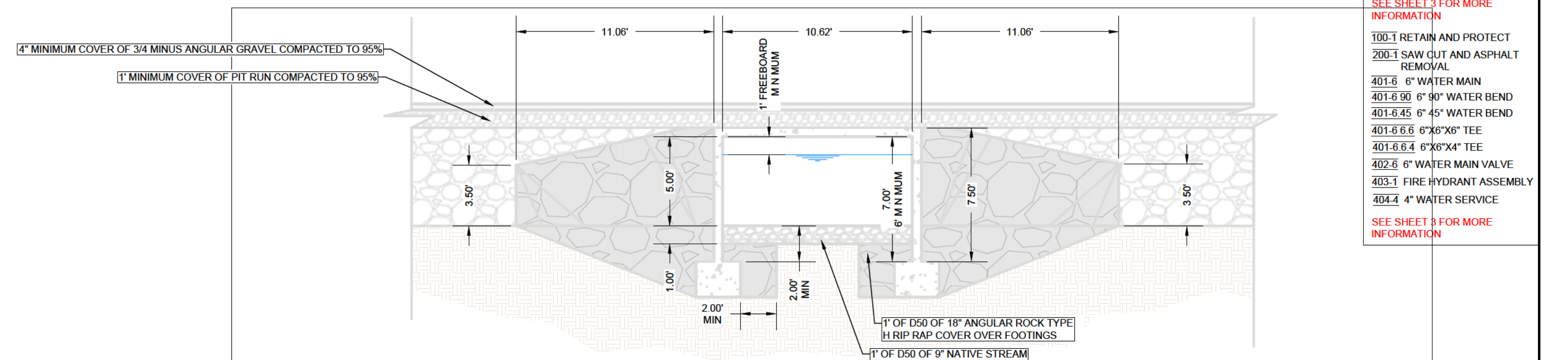

PRIVATE DRIVE CULVERT - PROFILE VIEW
TO BE DESIGNED BY OTHERS
NTS

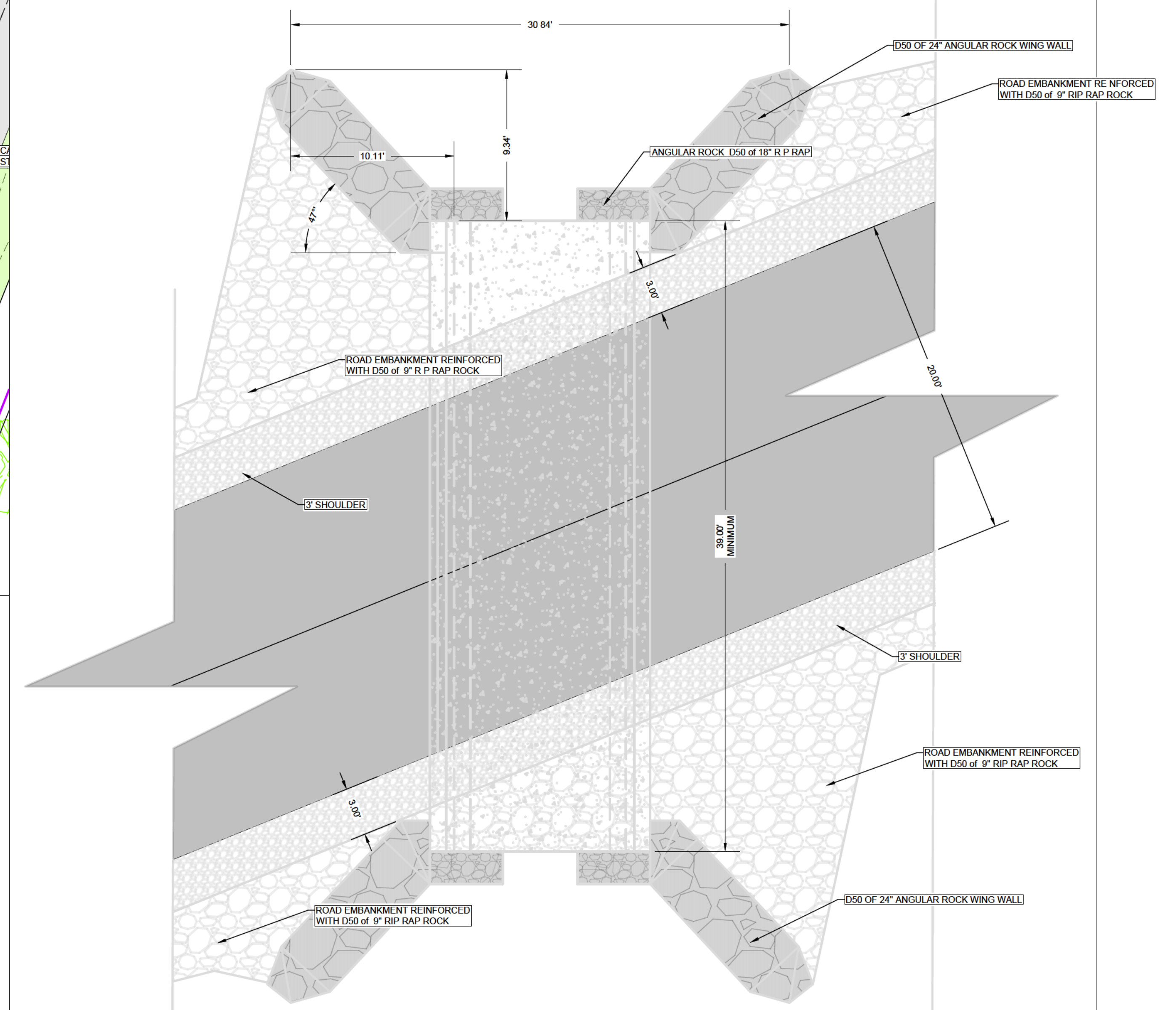

PRIVATE DRIVE CULVERT - PLAN VIEW
TO BE DESIGNED BY OTHERS
NTS

- SEE SHEET 3 FOR MORE INFORMATION
- 100-T RETAIN AND PROTECT
 - 200-T SAW CUT AND ASPHALT REMOVAL
 - 401.6 6" WATER MAIN
 - 401.6.90 6" 90° WATER BEND
 - 401.6.45 6" 45° WATER BEND
 - 401.6.6.6 6" X6" TEE
 - 401.6.6.4 6" X6" X4" TEE
 - 402.6 6" WATER MAIN VALVE
 - 403.1 FIRE HYDRANT ASSEMBLY
 - 404.4 4" WATER SERVICE
- SEE SHEET 8 FOR MORE INFORMATION

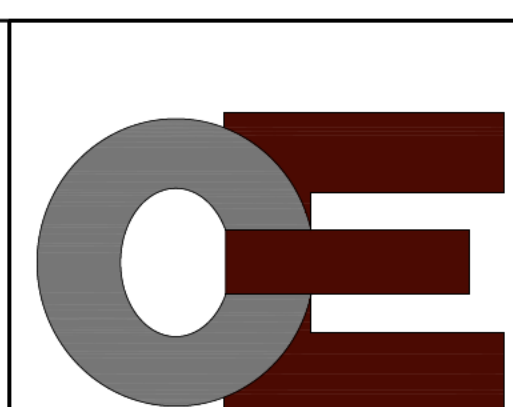

DRAWN BY	CHECK BY
MAK / AQT	BDJ
REVISIONS	DATE

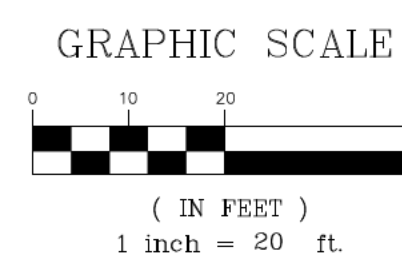

SHEET NAME: **MAHOGANY CREEK CROSSING**

PROJECT: **SKYLINE VIEW RANCH**

LOCATION: **TETON COUNTY, ID**

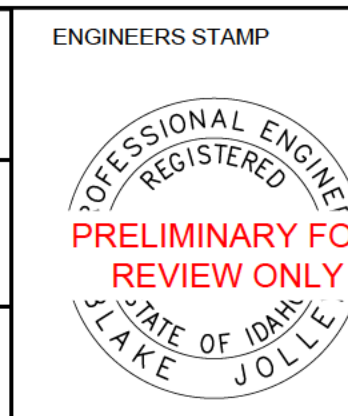

ENGINEERS STAMP

SHEET INFORMATION

JOB NO: 2021-105

DATE: July 1, 2024

SHEET SIZE: 24X36

VERTICAL EXAGGERATION: 1V = 10 H

PROJECT CONTACT: BARRY BAME, CONNECT ENGINEERING, 208-881-0061

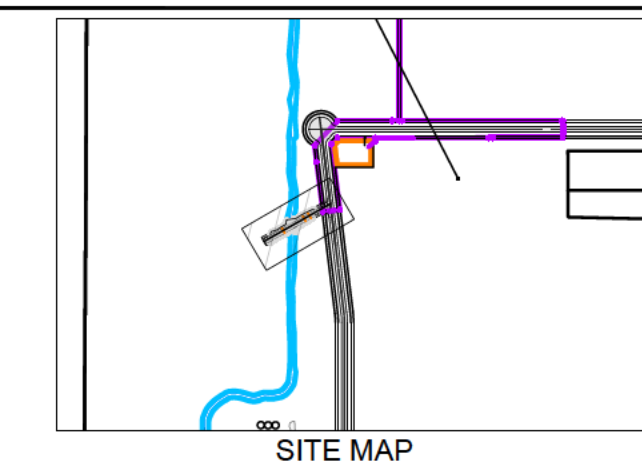

SHEET **C-6**

14

OF SHEETS

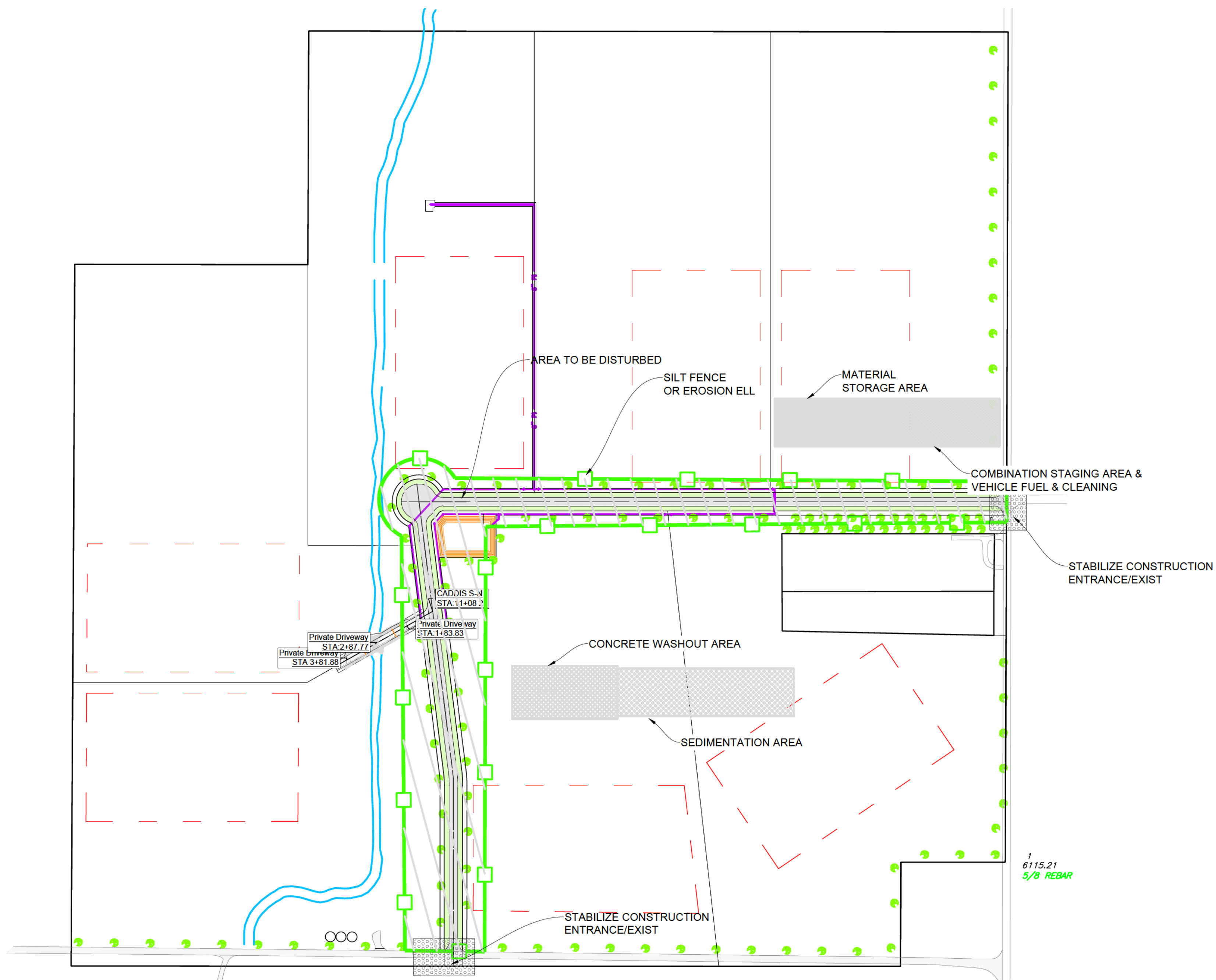

BEST MANAGEMENT PRACTICES NOTES

- This plan should be revised and updated to address changes in site conditions, new or revised government regulations, and additional on-site storm water pollution. Additional erosion control measures may be required.
- All revisions to this plan must be documented on the SWPPP Revision Documentation Form.
- Current versions of the SWPPP, the NOI, and the NOC will be kept on site for the duration of the project. These items will be available for the use of all operators and site personal involved with erosion and sediment controls, and be available to EPA visiting the site. A notice will be posted near the construction entrance during construction, containing the SWPPP, the NOI and the NOC.
- Fugitive dust blowing from the site shall be controlled by spraying water and dust control polymers as needed on dry areas of the site.
- The contractor will be responsible for supervision and inspection of all erosion and sedimentation controls and for ensuring the SWPPP is implemented.
- Prior to beginning earth-moving activities, including clearing and grubbing, all clearing limits, easements, setbacks, sensitive areas and their buffers will be clearly marked to prevent environmental damage both on and off the site.
- If sediment is accidentally transported on to the street it will be removed from the street surface on a daily basis.
- All off-site construction shall be stabilized at the end of the working day.
- All waste material will be collected and stored in a securely lidded dumpster. The dumpster will meet all local and state solid waste management regulations.
- Portable sanitary units will be provided for use by all workers for the entire project. Sanitary waste will be collected regularly for the portable units by an approved sanitary waste management contractor.
- All exposed soils will be stabilized with vegetation or covered no more than 14 days after the construction activity in that portion of the site has temporarily or permanently ceased.
- Existing and new vegetation will be maintained to the maximum extent practicable to prevent the contamination of storm water with sediment.
- The contractor shall be responsible for adjusting the erosion control measure, due to grade changes during the development of the project.
- Maintain on the site or have readily available sufficient oil and grease absorbing materials to contain and clean up fuel or chemical spills and leaks.
- Adequate energy dissipation, erosion control, and soil stabilization measures will be provided for all point source discharges of storm water, including run-on discharges and outlets for onsite discharges.
- Temporary and permanent swells and small detention ponds will be used as necessary to reduce the velocity of runoff and enhance particle settling.
- Consistent with the general permit requirements, all potential pollutants other than sediment will be handled and disposed of in a manner that does not affect contamination of stormwater.
- Materials used during construction with the potential to impact storm water, will be stored, managed, used, and disposed of in a manner that minimizes the potential for releases to the environment and especially in the storm water.
- If a spill of pollutants threatens storm water at the site, the spill response procedures must be implemented in a timely manner to prevent the release of pollutants.
- All temporary and permanent erosion and sediment control BMPs will be maintained and repaired as needed to assure continued performance of their intended use.
- All temporary erosion control and sediment control BMPs will be removed within 30 days after final site stabilization is achieved or after the temporary BMPs are no longer needed.
- Regardless of recommended maintenance schedule, all control measures and inspections shall be performed within 24 hours following any storm of 0.5 inches or greater. An inspection report shall be kept at all times and should be retained for at least three (3) years from the date the site is stabilized.
- All contractors providing services on the project which may cause storm water pollution will be given a copy of the SWPPP and appropriate training regarding stormwater pollution prevention.

NOTE:

- AFTER ASPHALT PAVING HAS TAKEN PLACE STORM WATER DEVELOPED WILL BE DIRECTED TO RETENTION BASINS AND PIPING PER THE APPROVED SITE PLAN AND PERCOLATE IN DESIGNATED AREAS
- INLET PROTECTION TO BE PLACED ON ALL STORM DRAIN INLETS AFTER INSTALLATION THROUGH THE DURATION OF THE PROJECT. CONTRACTOR RESPONSIBLE TO REMOVE AFTER CITY ACCEPTANCE.

LEGEND

- STORM WATER DRAINAGE
- AREA TO BE DISTURBED
- STABILIZE CONSTRUCTION ENTRANCE/EXIT
- COMBINATION STAGING AREA & VEHICLE EQUIPMENT CLEANING, FUELING AND MAIN.
- MATERIALS STORAGE AREA & STOCKPILE MANAGEMENT
- SILT FENCE OR EROSION EEL
- SEDIMENTATION AREA
- CONCRETE WASHOUT
- INLET PROTECTION

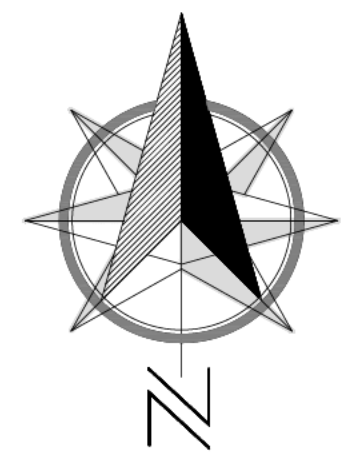
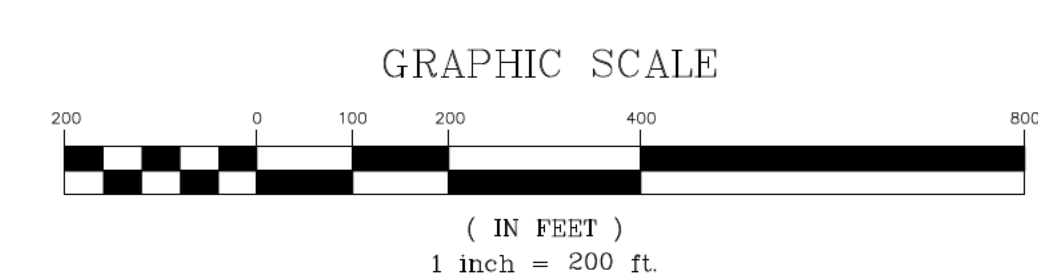

OFFSITE OPERATIONS	
START DATE	END DATE

TO BE FILLED OUT BY CONTRACTOR

SEQUENCE OF MAJOR ACTIVITIES		
ACTIVITY	START DATE	END DATE

TO BE FILLED OUT BY CONTRACTOR

POTENTIAL POLLUTANTS		
CHEMICAL	MSDS #	LOCATION

TO BE FILLED OUT BY CONTRACTOR

DRAWN BY MAK / AQT	CHECK BY BDJ
REVISIONS	DATE

THIS IS NOT A FULL SWPPP. OWNER OR CONTRACTOR IS RESPONSIBLE FOR A COMPLETE SWPPP



SHEET NAME: **BEST MANAGEMENT PRACTICES**

PROJECT: **SKYLINE VIEW RANCH**

LOCATION: **TETON COUNTY, ID**

ENGINEERS STAMP

SHEET INFORMATION

JOB NO: 2021-105

DATE: July 1, 2024

SHEET SIZE: 24x36

VERTICAL EXAGGERATION: 1V = 10 H

PROJECT CONTACT:
BARRY BAME
CONNECT ENGINEERING
208-881-0881

SHEET

C-12

14

OF SHEETS

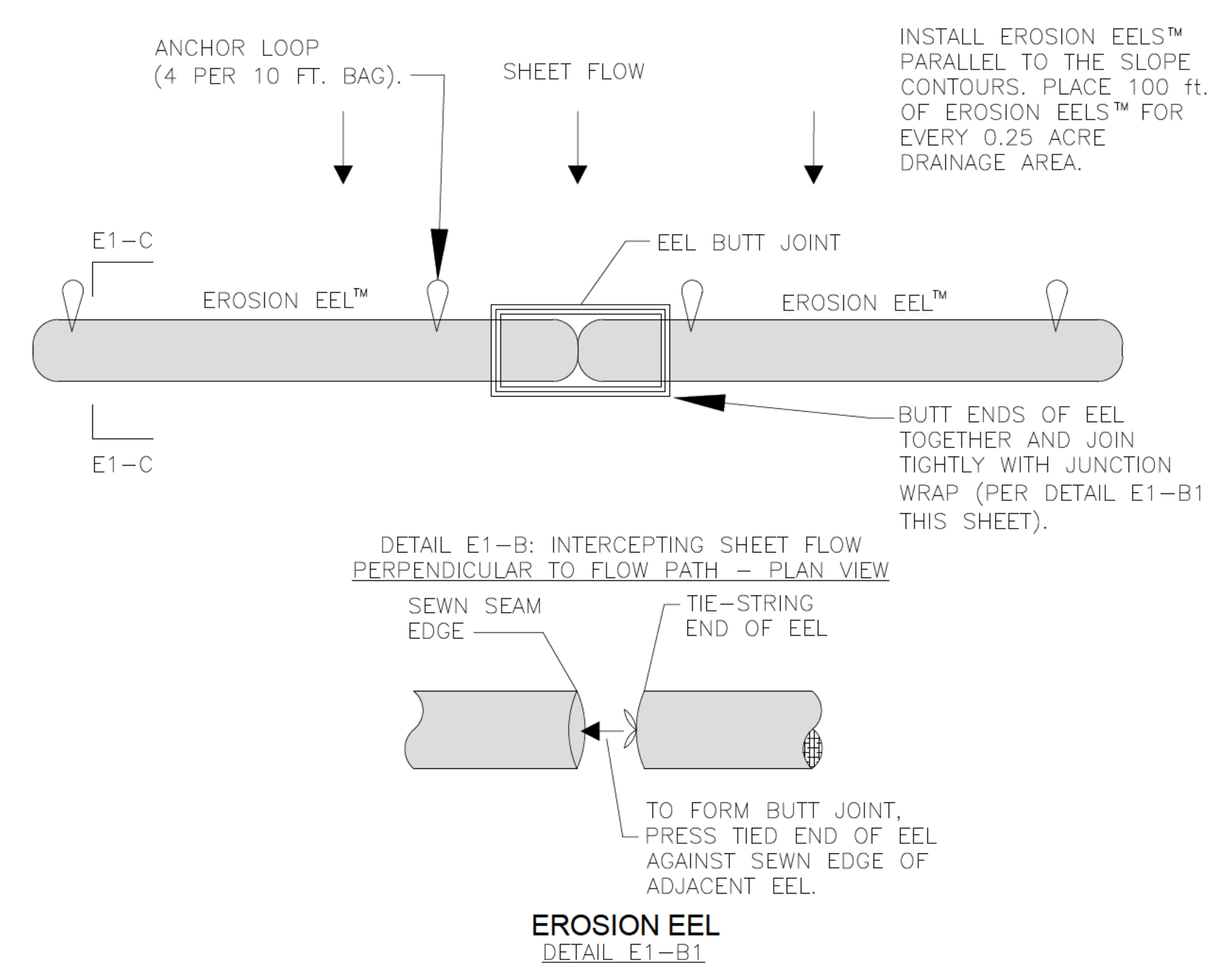
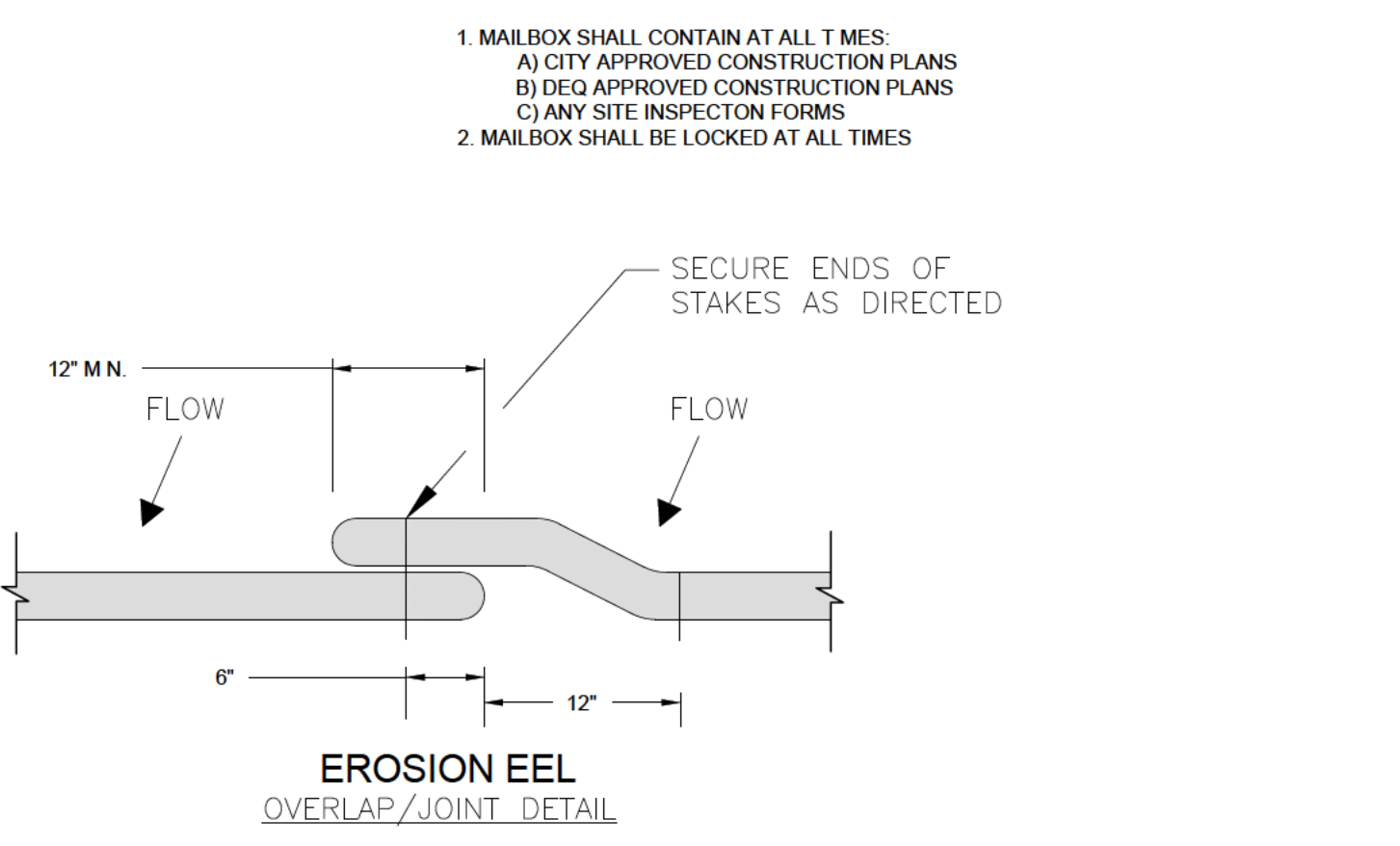
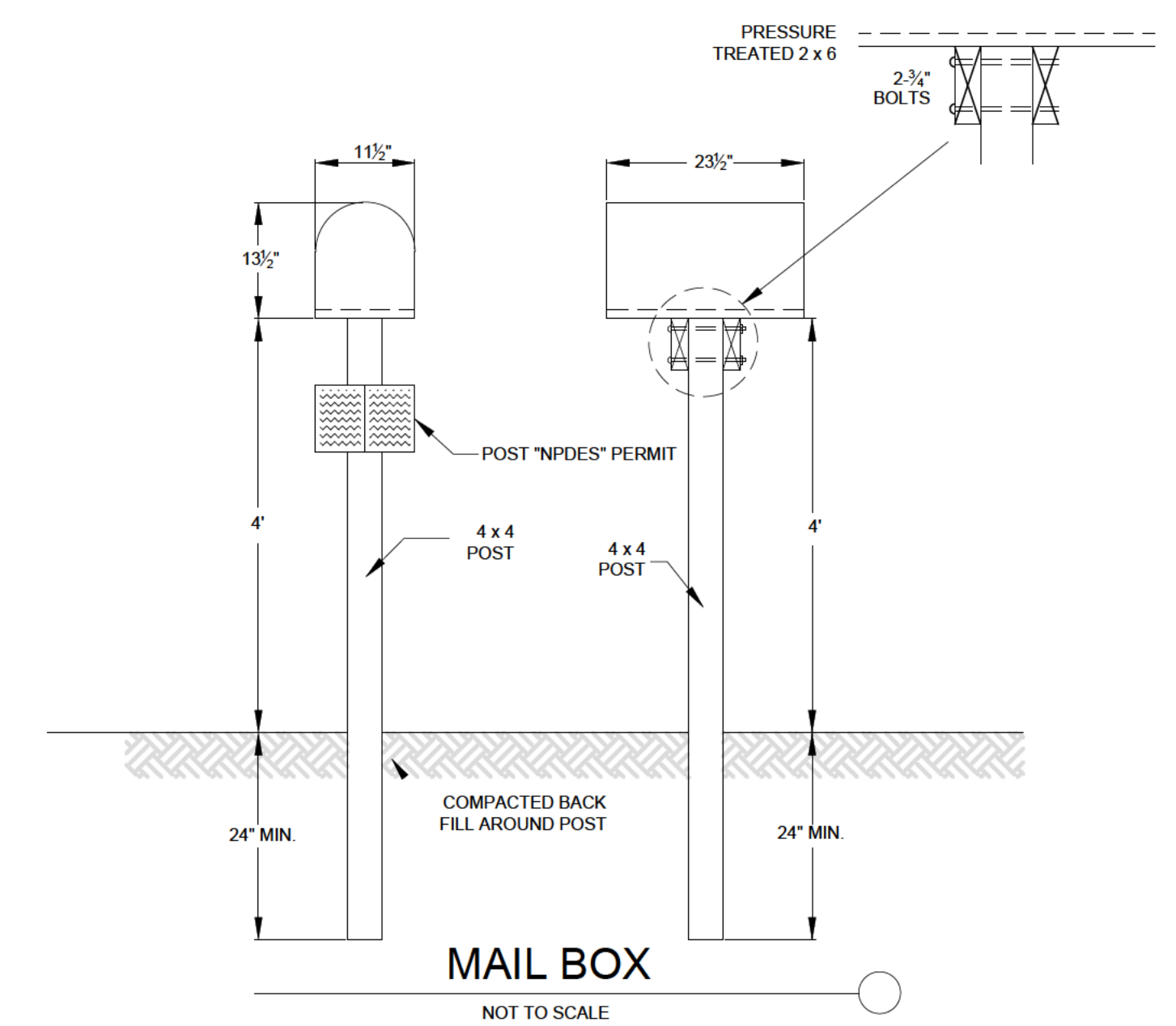
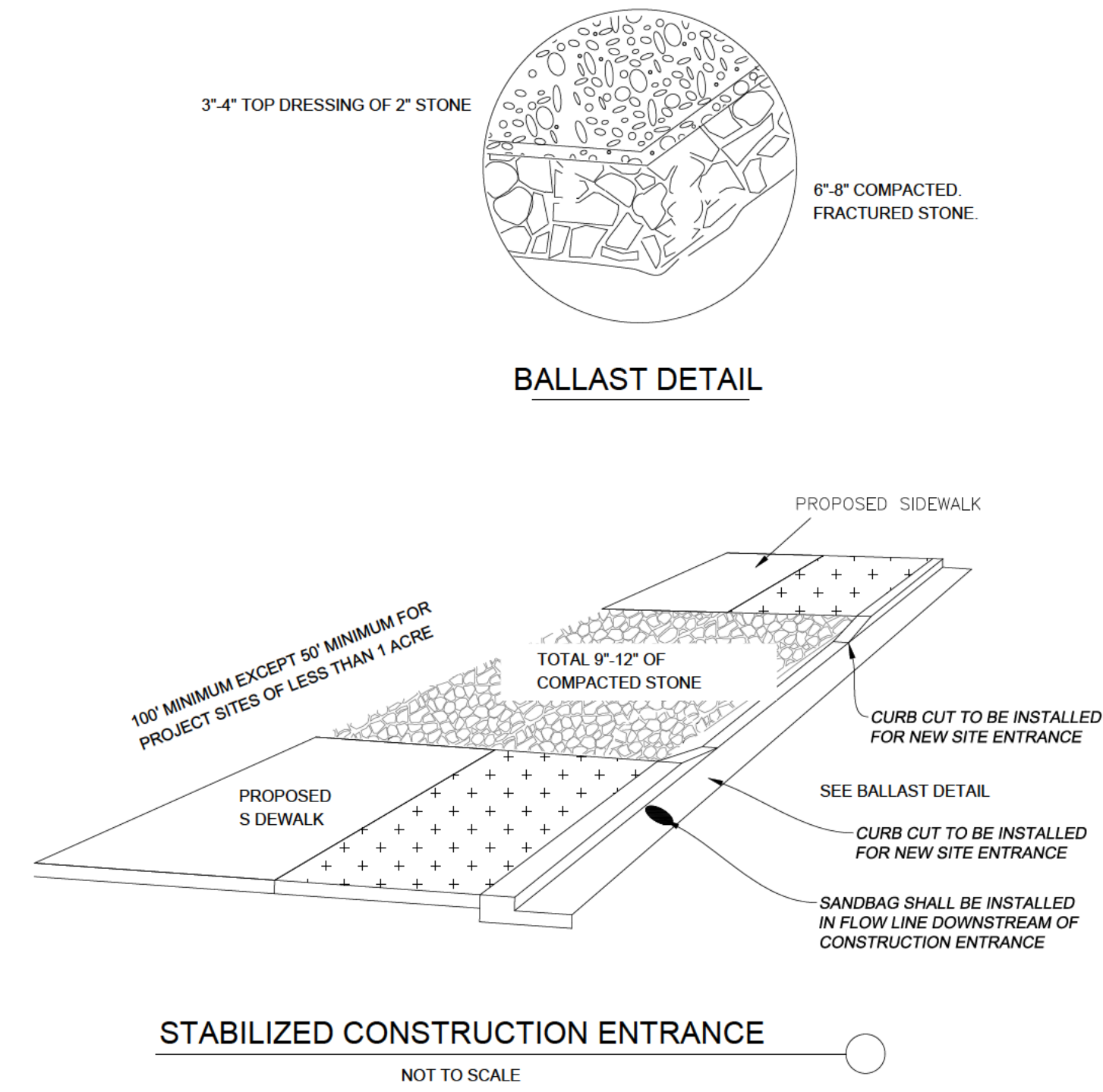
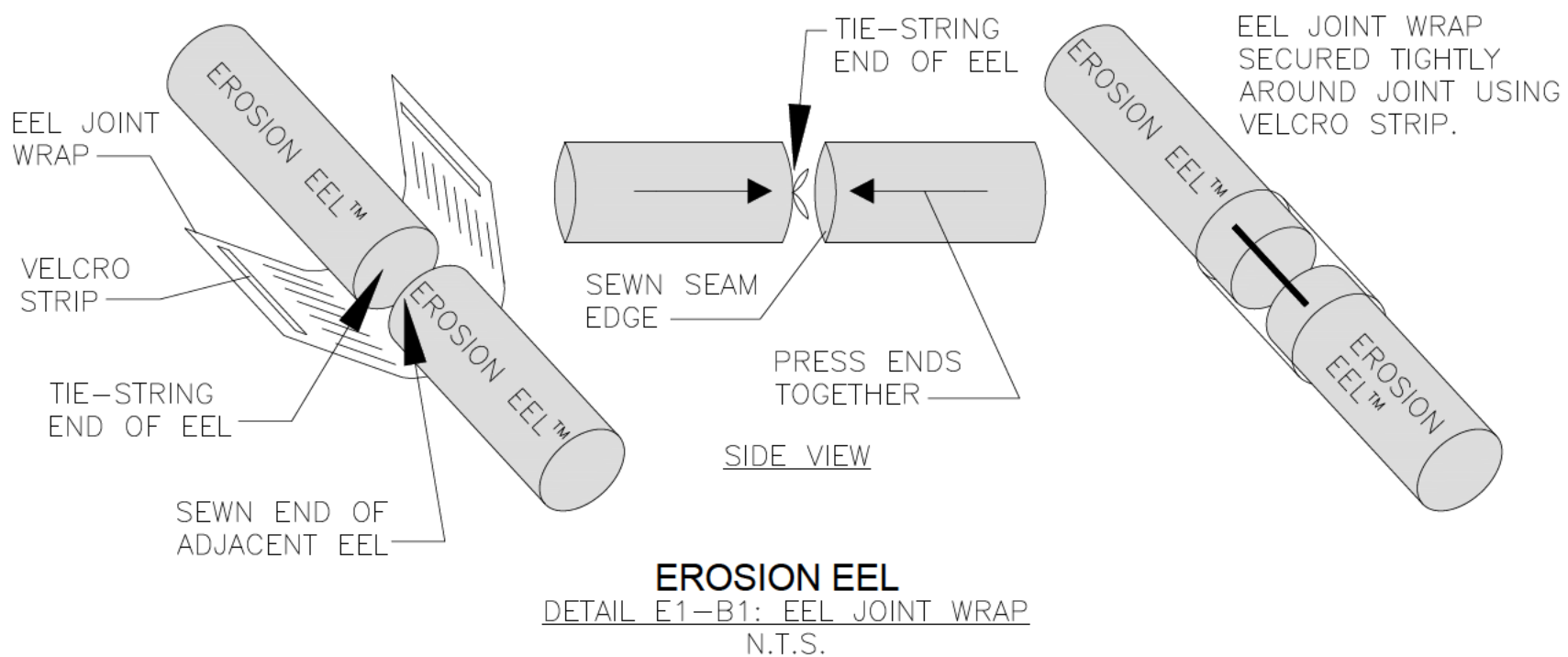
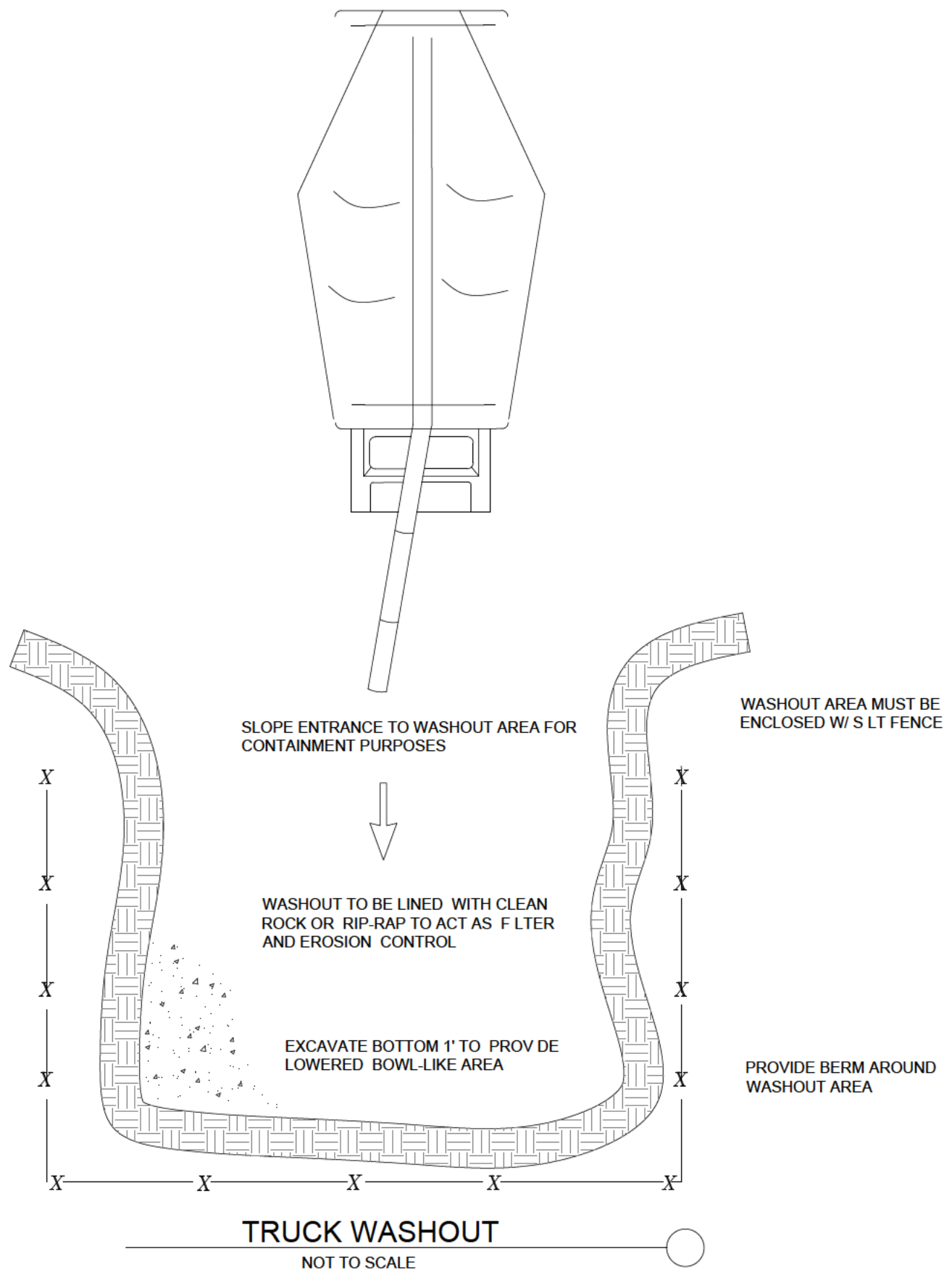
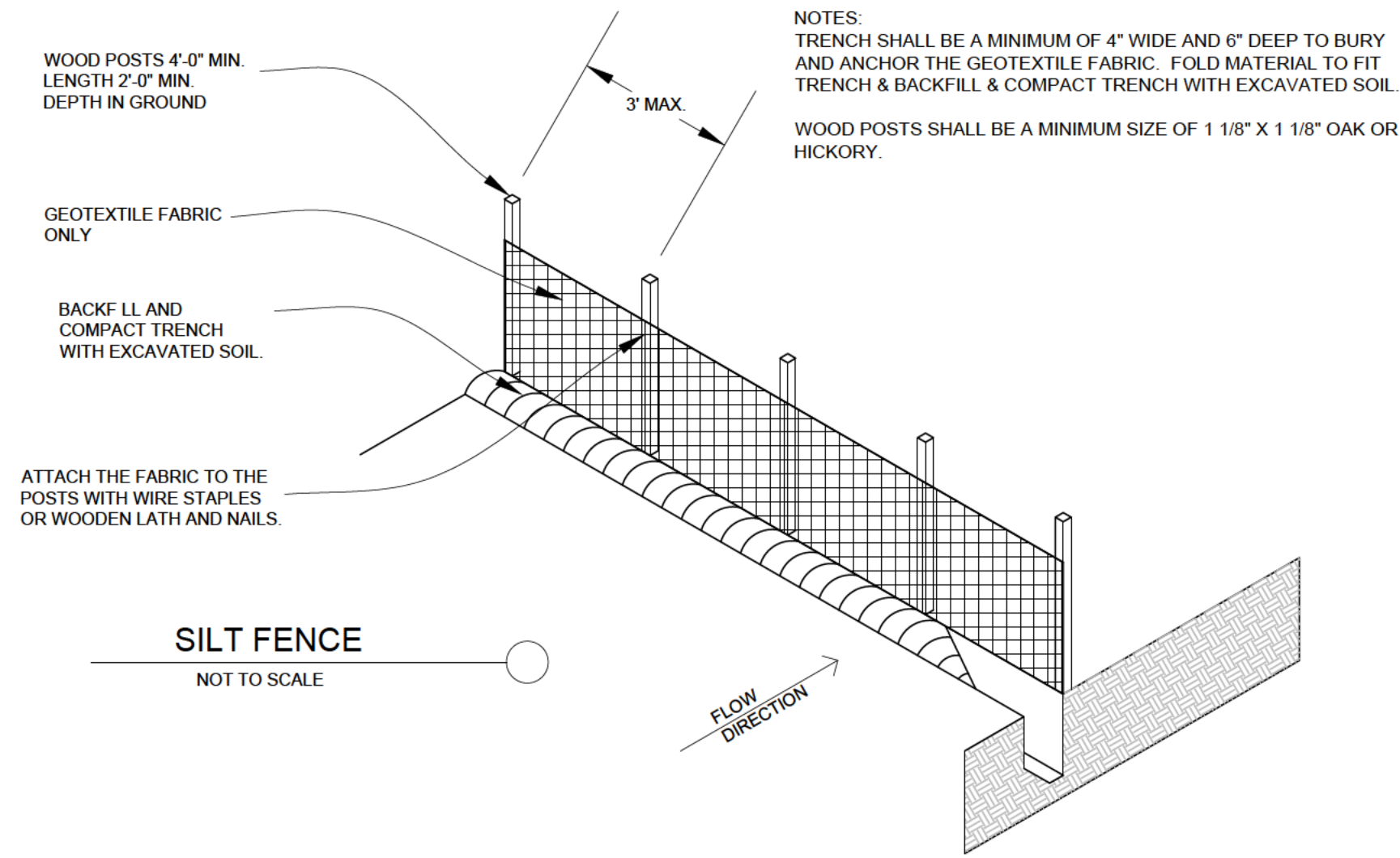

- GENERAL NOTES:**
- EROSION EELS USED IN PERIMETER CONTROL APPLICATIONS SHALL HAVE A SPECIFICATION MIXTURE 1.1 OR 1.2.
 - MIXTURE SPECIFICATION 1.1: A FILTER MIXTURE COMPRISED OF 50% SHREDDED RUBBER AND 50% WOOD CHIP PARTICLES BY VOLUME. THE SHREDDED RUBBER SHALL BE WASHED AND PROCESSED TO REMOVE MOST, IF NOT ALL, METAL COMPONENTS. THE RUBBER SHALL BE DERIVED FROM RECYCLED TIRES AND SHALL BE SHREDDED TO PRODUCE A MAXIMUM PARTICLE SIZE OF +/- 3/4 INCH. THE WOOD CHIPS SHALL BE PRODUCED FROM HARDWOOD TREES AND SHALL CONFIRM TO AASHTO CERTIFICATION SPECIFICATION MP 9-03.
 - MIXTURE SPECIFICATION 1.2: A FILTER MIXTURE COMPRISED OF 1/3 SHREDDED RUBBER, 1/3 WOOD CHIPS, AND 1/3 RECYCLED SYNTHETIC FIBERS. THE SHREDDED RUBBER SHALL BE WASHED AND PROCESSED TO REMOVE MOST, IF NOT ALL, METAL COMPONENTS. THE RUBBER SHALL BE DERIVED FROM RECYCLED TIRES AND SHALL BE SHREDDED TO PRODUCE A MAXIMUM PARTICLE SIZE OF +/- 3/4 INCH. THE WOOD CHIPS SHALL BE PRODUCED FROM HARDWOOD TREES AND SHALL CONFIRM TO AASHTO CERTIFICATION SPECIFICATION MP 9-03. THE SYNTHETIC FIBERS SHALL BE PRODUCED FROM RECYCLED, MANUFACTURED MATERIALS, SUCH AS, BUT NOT LIMITED TO, PRE-CONSUMER SCRAP CARPET, TIRE CHORD, AND TIRE FIBER MATERIALS.
 - EROSION EELS SHALL BE MANUFACTURED FROM A WOVEN GEOTEXTILE COVERING WITH INTERIOR FILTER MATERIALS SUCH AS 100% SHREDDED RUBBER (MIXTURE SPECIFICATION 1.0, 50% SHREDDED RUBBER/50% AASHTO-CERTIFIED WOOD CHIPS (MIXTURE SPECIFICATION 1.1).
 - LENGTHS OF EROSION EELS SHALL BE EITHER A NOMINAL +/-10 FT. OR +/- 4.5 FT. NOMINAL DIAMETER SHALL BE +/-9.5 INCHES.
 - EROSION EELS CAN BE PLACED AT THE TOP, ON THE FACE, OR AT THE TOE OF SLOPES TO INTERCEPT RUNOFF, REDUCE FLOW VELOCITY, RELEASE THE RUNOFF AS SHEET FLOW AND PROVIDE REMOVAL OF SEDIMENT FROM THE RUNOFF.
 - EROSION EELS SHALL BE INSTALLED ALONG THE GROUND CONTOUR, AT THE TOE OF SLOPES, AT AN ANGLE TO THE CONTOUR TO DIRECT FLOW AS A DIVERSION BERM, AROUND INLET STRUCTURES, IN A DITCH AS A CHECK DAM TO HELP REDUCE SUSPENDED SOLIDS LOADING AND RETAIN SEDIMENT, OR AS A GENERAL FILTER FOR ANY DISTURBED SOIL AREA.
 - NO TRENCHING IS REQUIRED FOR INSTALLATION OF EROSION EELS
 - PREPARE BED FOR EEL INSTALLATION BY REMOVING ANY LARGE DEBRIS INCLUDING ROCKS, SOIL CLODS, AND WOODY VEGETATION. EROSION EELS CAN ALSO BE PLACED OVER PAVED SURFACES INCLUDING CONCRETE AND ASPHALT WITH NO SURFACE PREPARATION REQUIRED.
 - RAKE BED AREA WITH A HAND RAKE OR BY DRAG HARROW.
 - DO NOT PLACE EEL DIRECTLY OVER RILL AND GULLIES UNTIL AREA HAS BEEN HAND-EXCAVATED AND RAKED TO PROVIDE A LEVEL BEDDING SURFACE. ALL SURFACES SHALL BE UNIFORMLY COMPACTED FOR MAXIMUM SEATING OF EELS IN PLACE.
 - FOR LOCATIONS WHERE EELS WILL BE PLACED IN CONCENTRATED FLOWS (SUCH AS CHECK DAMS, INLET PROTECTION) AND FOR PERIMETER CONTROLS AT PRIMARY DISCHARGE LOCATIONS, BED THE EELS IN A FLOCMAT CRADLE PER THE DETAILED DRAWINGS.
 - FOR DITCH APPLICATIONS, THE MAXIMUM DRAINAGE AREA SHALL BE 10 ACRES.
 - IF MORE THAN ONE EROSION EEL IS PLACED IN A ROW, THE EELS SHALL BE OVERLAPPED A MINIMUM OF 12 INCHES TO PREVENT FLOW AND SEDIMENT FROM PASSING THROUGH THE FIELD JOINT. COMPRESS THE TWO EELS OF THE OVERLAP TIGHTLY TOGETHER EITHER BY HAND OR MANUFACTURER-APPROVED MECHANIZED MEANS.
 - WHEN USED IN DITCHES AS A CHECK DAM, EROSION EELS SHALL BE INSTALLED PER MANUFACTURER'S DETAILS.
 - FOR CHECK DAM APPLICATIONS, EROSION EELS SHALL BE PLACED PERPENDICULAR TO THE FLOW OF THE WATER. EROSION EELS SHALL CONTINUE UP THE SIDES SLOPES A MINIMUM OF 3 FEET ABOVE THE DESIGN FLOW DEPTH.
 - EROSION EELS SHALL REMAIN IN PLACE UNTIL FULLY ESTABLISHED VEGETATION HAS COMPLETELY DEVELOPED OR UNTIL THE STORAGE CAPACITY/FUNCTIONAL LIFE OF THE EEL HAS BEEN EXHAUSTED (REQUIRING REPLACEMENT WITH NEW EELS).
 - ANCHORING POSTS FOR CHECK DAM APPLICATIONS SHALL HAVE A MINIMUM WEIGHT OF 1.25 LBS/FT STEEL T-POSTS (5 TO 7 FT. LENGTHS) ROLLED FROM HIGH CARBON STEEL. POSTS SHOULD BE HOT-DIP GALVANIZED OR COATED WITH A WEATHER-RESISTANT PAINT FOR STEEL APPLICATION. POSTS SHOULD BE EQUIPPED WITH A METAL ANCHOR PLATE. INSTALL PER DETAILS ON THIS SHEET.
 - PLACE T-POSTS THROUGH HANDLE OF BAGS. DO NOT DRIVE POSTS THROUGH EROSION EELS. T-POSTS ARE TO BE EMBEDDED A MINIMUM OF 2 FT INTO GROUND.

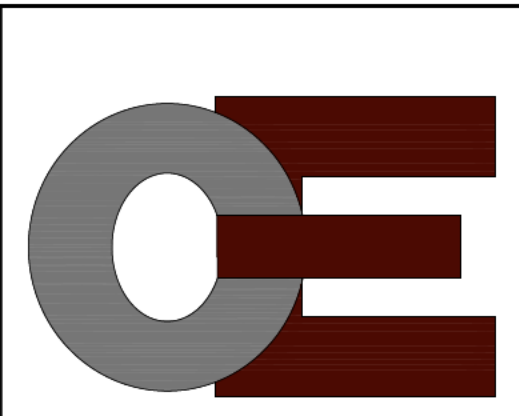

DRAWN BY	CHECK BY
MAK / AQT	BDJ
REVISIONS	DATE

THIS IS NOT A FULL SWPPP. OWNER OR CONTRACTOR IS RESPONSIBLE FOR A COMPLETE SWPPP



SHEET NAME:	BEST MANAGEMENT DETAILS
PROJECT:	SKYLINE VIEW RANCH
LOCATION:	TETON COUNTY, ID

ENGINEERS STAMP

PRELIMINARY FOR REVIEW ONLY

SHEET INFORMATION

JOB NO: 2021-105

DATE: July 1, 2024

SHEET SIZE: 24X36

VERTICAL EXAGGERATION: 1V = 10 H

PROJECT CONTACT:
BARRY BAME
CONNECT ENGINEERING
208-881-0881

SHEET	C-13
OF	14
SHEETS	

StreamStats Report

Region ID: ID
 Workspace ID: ID20240709213308570000
 Clicked Point (Latitude, Longitude): 43.69366, -111.20743
 Time: 2024-07-09 15:33:32 -0600

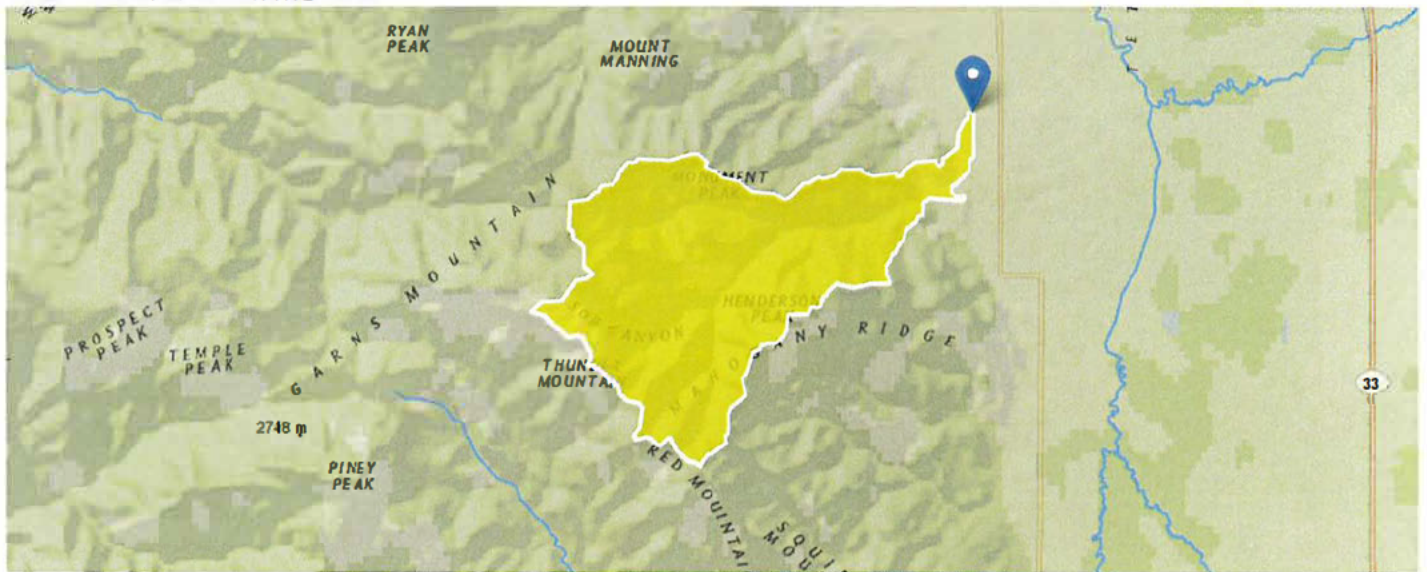

Collapse All

> Basin Characteristics

Parameter Code	Parameter Description	Value	Unit
BSLDEM30M	Mean basin slope computed from 30 m DEM	39.6	percent
DRNAREA	Area that drains to a point on a stream	9.69	square miles
ELEV	Mean Basin Elevation	7340	feet
FOREST	Percentage of area covered by forest	65	percent
PRECIP	Mean Annual Precipitation	26.1	inches
PRECPRIS10	Basin average mean annual precipitation for 1981 to 2010 from PRISM	39	inches
SLOP30_30M	Percent area with slopes greater than 30 percent from 30-meter DEM.	73.2	percent

> Low-Flow Statistics

Low-Flow Statistics Parameters [Low Flow Region 8 2006 5053]

Parameter Code	Parameter Name	Value	Units	Min Limit	Max Limit
DRNAREA	Drainage Area	9.69	square miles	6.6	874.8
BSLDEM30M	Mean Basin Slope from 30m DEM	39.6	percent	6.15	53.2

Low-Flow Statistics Flow Report [Low Flow Region 8 2006 5053]

PIL: Lower 90% Prediction Interval, PIU: Upper 90% Prediction Interval, ASEp: Average Standard Error of Prediction, SE: Standard Error, PC: Percent Correct (other – see report)

Statistic	Value	Unit	SE	ASEp
1 Day 10 Year Low Flow	2.14	ft ³ /s	55	56

Statistic	Value	Unit	SE	ASEp
7 Day 2 Year Low Flow	2.94	ft ³ /s	37	38
7 Day 10 Year Low Flow	2.38	ft ³ /s	37	38
30 Day 5 Year Low Flow	2.34	ft ³ /s	34	35

Low-Flow Statistics Citations

Hortness, J.E., 2006, Estimating Low-Flow Frequency Statistics for Unregulated Streams in Idaho: U.S. Geological Survey Scientific Investigations Report 2006-5035, 31 p. (<http://pubs.usgs.gov/sir/2006/5035/pdf/sir20065035.pdf>)

➤ Peak-Flow Statistics

Peak-Flow Statistics Parameters [Peak Flow Region 6 and 8 2016 5083]

Parameter Code	Parameter Name	Value	Units	Min Limit	Max Limit
DRNAREA	Drainage Area	9.69	square miles	2.77	3740
PRECPRI10	Mean Annual Precip PRISM 1981 2010	39	inches	18.9	54.6

Peak-Flow Statistics Flow Report [Peak Flow Region 6 and 8 2016 5083]

PIL: Lower 90% Prediction Interval, PIU: Upper 90% Prediction Interval, ASEp: Average Standard Error of Prediction, SE: Standard Error, PC: Percent Correct (other -- see report)

Statistic	Value	Unit	PIL	PIU	ASEp
80-percent AEP flood	108	ft ³ /s	38.5	303	66.9
66.7-percent AEP flood	132	ft ³ /s	49	355	63.7
50-percent AEP flood	163	ft ³ /s	62.6	424	61.3
42.9-percent AEP flood	179	ft ³ /s	68.8	466	61.1
20-percent AEP flood	238	ft ³ /s	90.6	625	61.7
10-percent AEP flood	295	ft ³ /s	109	796	63.8
4-percent AEP flood	364	ft ³ /s	127	1040	68.1
2-percent AEP flood	413	ft ³ /s	139	1230	71.5
1-percent AEP flood	479	ft ³ /s	154	1490	75.1
0.5-percent AEP flood	529	ft ³ /s	163	1720	78.8
0.2-percent AEP flood	617	ft ³ /s	179	2130	84

Peak-Flow Statistics Citations

Wood, M.S., Fosness, R.L., Skinner, K.D., and Veilleux, A.G., 2016, Estimating peak-flow frequency statistics for selected gaged and ungaged sites in naturally flowing streams and rivers in Idaho: U.S. Geological Survey Scientific Investigations Report 2016-5083, 56 p. (<http://dx.doi.org/10.3133/sir20165083>)

➤ September Flow-Duration Statistics

September Flow-Duration Statistics Parameters [Monthly Annual Region 8 2001 4093]

Parameter Code	Parameter Name	Value	Units	Min Limit	Max Limit
DRNAREA	Drainage Area	9.69	square miles	6.6	874.8
FOREST	Percent Forest	65	percent	2.3	93.9
PRECIIP	Mean Annual Precipitation	26.1	inches	14.2	56